



# CAMPING PRODUCTS



CAMPING PODS

HALF PODS

SLEEPING BARRELS

CAMPING CABINS

DOMES

GLAMPING CUBES



REAL PRODUCTS FOR REAL PEOPLE

UAB Viking Industrier is a Norwegian capital company located in Venta town, Lithuania.

We have gathered a team of professionals whose main goal is to design, produce and sell high quality wooden products and accessories for leisure.

# ABOUT CAMPING PRODUCTS

## TIMBER

### SPRUCE

We mainly use FSC-certified spruce wood. Every single board used for our camping product has its own individual character and history, and this makes our product a real natural and unique product.

The colours range from creamy white to light yellow and to red-brown. Heartwood is not distinct from sapwood.

Spruce is straight-grained with thin and regular texture. Resin canals are rather common. The wood is soft, low in weight and has medium density. The strength properties are good. Sawing and machining is easy, also assembling.

### THERMOWOOD

Thermowood is a natural and renewable resource for construction, but has greater stability and resistance to rot making it a far more dependable product. This is now ideal for cladding buildings as it is lower cost than some of the traditional cladding timbers, but has comparable longevity and greater stability than other timbers products. By selecting your camping product with thermowood cladding you ensure a long lifespan for the product and less maintenance time and cost to you.



Timber for Camping Pod walls. 1. Thermowood (44 mm). 2. Spruce (38 mm). 3. Spruce (58 mm)

### ROOF SHINGLES

6 layer bitumen tiles consists of durable and highly resistant fiber glass base coated with polymer- reinforced bitumen mix made of high quality bitumen and aggregate. The top layer of tiles is surfaced with mineral granules that lend color to the tiles and ensure high UV protection and other weather conditions resistance qualities.

The granules are painted in high temperature using thermal method pigment being burned-in into the surface of granules what guarantees long durability of the color. The bottom of tiles is coated with adhesive polymer-reinforced bitumen layer protected with easily removed silicon membrane.



### RECOMMENDATIONS FOR WOOD CARE

You should not forget that wood is a natural material, it changes and moves depending on weather conditions. Large and small cracks, color tone differences and other changes, as well as a changing structure of wood are not defects, but a result of wood growing and a feature of wood as a natural material. Natural wood (not impregnated) becomes grayish after being left untouched for a while, and can turn blue and become moldy. You should immediately process it with wood preservative to protect the wooden parts of our manufactured products.

We definitely recommend that you process the door and windows with a wood preservative, and do it on both sides (inside and outside), because the doors and windows can deform. Also, you should pre-treat the Camping Cabins floor

panels with a wood preservative, especially the bottom sides of the panels, to which you will no longer have access when the Cabin is assembled. Only this will prevent moisture penetration.

In general, we recommend for the conclusive finishing a weather protection paint that will protect wood from moisture and UV radiation after the product is assembled.

Consult a specialist regarding paints suitable for unprocessed softwood and follow the paint manufacturer's instructions. Your Camping Product service life will be much longer after it will be properly painted. We recommend that you inspect your product thoroughly once every six months.

# CAMPING PODS

## COMFORTABLE OUTDOOR LIVING

Camping Pods are a great choice for tourists and holiday makers who want to relax after an adventure. Because of the feeling of a home's atmosphere in outdoor setting, this product is very much liked by camping owners or festival organizers.



# CAMPING POD 2.4 x 4.8



### Recommended furnishings:

In living room 2 wooden poufs, table and bench; Bedroom with double wooden bed which can be transformed into a sofa

Small terrace:  
(W x D) 600 x 2321 mm

Inside are two rooms:  
living room and bedroom



Try camping in a high quality camping pod, it is ideal choice for a camping place. Pod has a small entrance and two rooms inside: a 2 m length sleeping room and 2 m long sitting room. Camping pod is made from spruce. Thickness of the camping pod walls is 38 mm; thickness of the solid wood flooring is 28 mm.

## STANDARD SET

- Pod made from spruce;
- Roof covered with bitumen shingles of your selected color;
- Opening window in the back wall;
- Double doors with a lock and the double glass windows;
- Two rooms inside: a sleeping and a sitting room;
- Wall partition with entrance.

## TECHNICAL SPECIFICATION

Shape	Pod
External dimension (W x L)	2321 x 4800 mm
Total high (H)	2580 mm
Inside area	9.3 m <sup>2</sup>
Size of windows (W x H)	680 x 704 mm
Size of doors (W x H)	1020 x 1900 mm
Size of terrace (W x D)	2321 x 600 mm
Number of windows	1
Number of opening windows	1
Group of people	2-4 persons
Weight	1880 kg
Wood	Spruce / Thermowood
Wall thickness	38 mm

## OPTIONS

### ROOF COLOR

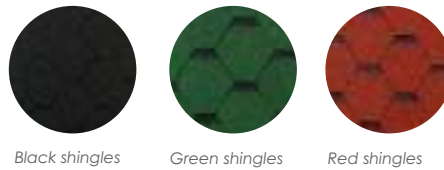

Black shingles      Green shingles      Red shingles

### LAYOUT

- Pod with terrace 0.6 m: 1st room 1.9 m / 2nd room 2 m;
- Pod without terrace: 1st room 2.4 m / 2nd room 2 m.

### THICKNESS OF THE WALL

- 38 mm thick spruce wood: standard;
- 58 mm thick spruce wood: optional;

### POD BACK WALL

- 38 mm spruce wood wall: standard;
- Full glass back wall: optional (10 mm tempered glass).

### TRANSPORTATION AND ASSEMBLY

The Camping Pod is delivered to a customer fully assembled or not-assembled, but fully complete, with detailed assembly instructions, drawings and packed on a pallet (KIT). Two people can assemble Camping Pod 2.4 x 4.8 m in 10 hours.

**Size of a assembled cargo (L x W x H):**

4.9 x 2.4 x 2.6 m.

**Size of a KIT (L x W x H):** 4.9 x 1.2 x 1.25 m.

## INSIDE PLAN

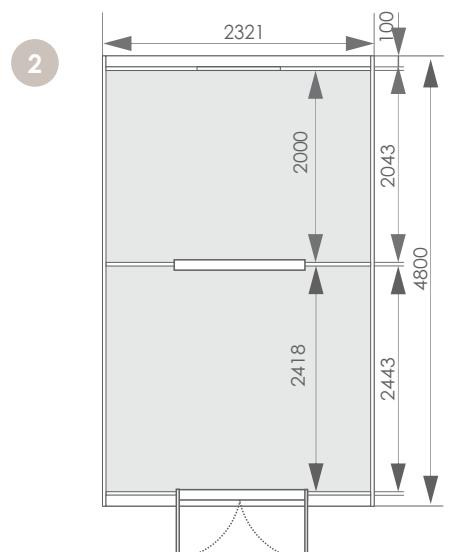
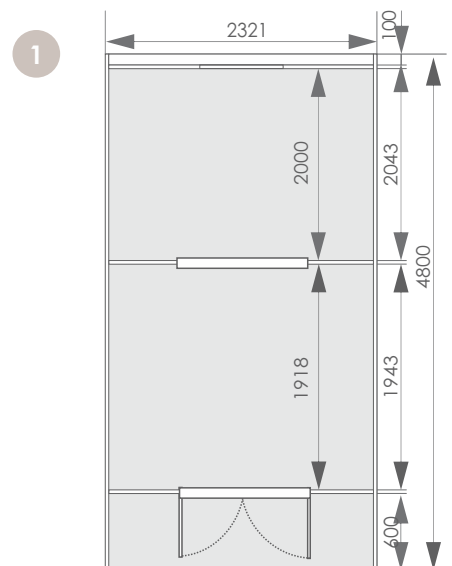



The front of Camping Pod 3.2 x 4.8 m



The interior of Camping Pod 3.2 x 4.8 m



Comfortable wooden pouf with storage

# CAMPING POD 2.4 x 4.8



INSULATED

## INSIDE PLAN

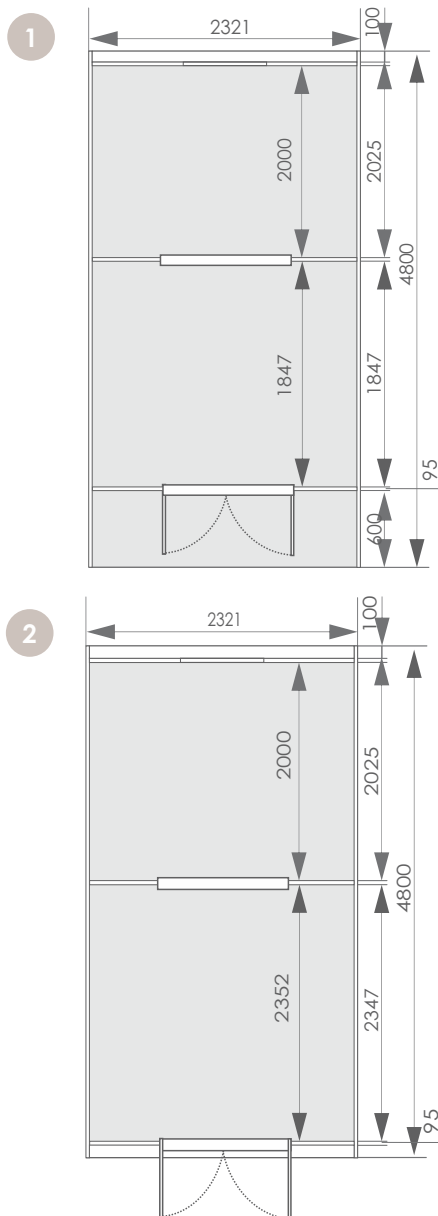

## STANDARD SET

- Pod made from spruce with insulated walls, floor;
- Roof covered with bitumen shingles of your selected color;
- One opening window in the back wall;
- Double doors with a lock and the double glass windows;
- Two rooms inside: sleeping and living room;
- Wall partition with the entrance.

## TECHNICAL SPECIFICATION

Shape	Pod
External dimension (W x L)	2321 x 4800 mm
Size of terrace (W x D)	2321 x 600 mm
Total high (H)	2452 mm
Inside area	9 m <sup>2</sup>
Size of window (W x H)	755 x 832 mm
Size of doors (W x H)	1020 x 1700 mm
Number of window	1 double
Number of opening window	1
Group of people	4-8 persons
Weight	1600 kg (without furnitures)
Wood	Spruce
Wall thickness	38 mm

## TRANSPORTATION AND ASSEMBLY

The Camping Pod is delivered to a customer **assembled** or **not-assembled**, but fully complete, with detailed assembly instructions and drawings, and packed on a pallet (KIT). Two people can assemble camping pod in 12 hours.  
**Size of KIT (L x W x H):** 4.9 x 1.2 x 2.6 m.  
**Size of assembled cargo is (L x W x H):** 4.9 x 2.4 x 2.6 m.

## INSULATION

### Wall insulation

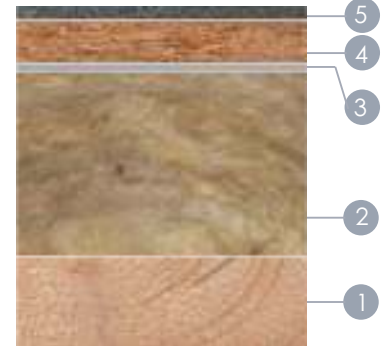

1. Wall made from spruce (38 mm).
2. Stonewool (50 mm).
3. Wind insulating film (1mm).
4. OSB panel (9 mm).
5. Bitumen shingles (3 mm).

### Panel insulation



1. Wall made from spruce (38 mm).
2. Stonewool (50 mm).
3. Wind insulating film (1mm).
4. Wall made from spruce (12 mm) and diffusion film.

### Floor insulation



1. Floor made from spruce (28 mm).
2. Wind insulating film (1mm).
3. Stonewool (50 mm).
4. OSB panel (9 mm) with plastic film.

## LAYOUT

1. **With terrace 0.6 m:** 1st room 1.8 m; 2nd room 2 m length;
2. **Without terrace:** 1st room 2.3 m and 2nd room 2 m length.

## ROOF COLOR

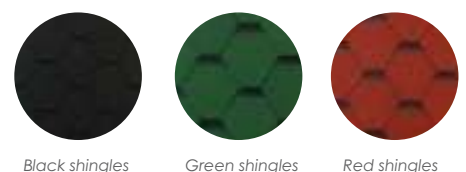

Black shingles

Green shingles

Red shingles

# CAMPING POD 2.4 x 5.9

## WITH SIDE ENTRANCE



### STANDARD SET

- Pod made from spruce wood;
- Roof covered with bitumen shingles of your selected color;
- Double opening windows in the side walls;
- Double doors with a lock and the double glass windows;
- Inside wall dividing sleeping and living zones.

### TECHNICAL SPECIFICATION

Shape	Pod
External dimension (W x L)	5900 x 2400 mm
Total high (H)	2280 mm
Inside area	12 m <sup>2</sup>
Size of window (W x H)	680 x 710 mm
Size of doors (W x H)	1020 x 1700 mm
Number of windows	2 double
Group of people	2-4 persons
Wood	Spruce
Wall thickness	38 mm

### OPTIONS



**EXTERIOR PAINTING**

Exterior painting. Body color;

Exterior painting. Finishing parts color.

**POD SIDE WALLS**

38 mm spruce wood wall with windows: standard;

Full glass side walls: optional (10 mm tempered glass).

**TRANSPORTATION AND ASSEMBLY**

The Camping Pod is delivered to a customer fully assembled with use and maintenance recommendations.

Size of assembled cargo is (L x W x H): 6 x 2.4 x 2.6 m.

### INSIDE PLAN

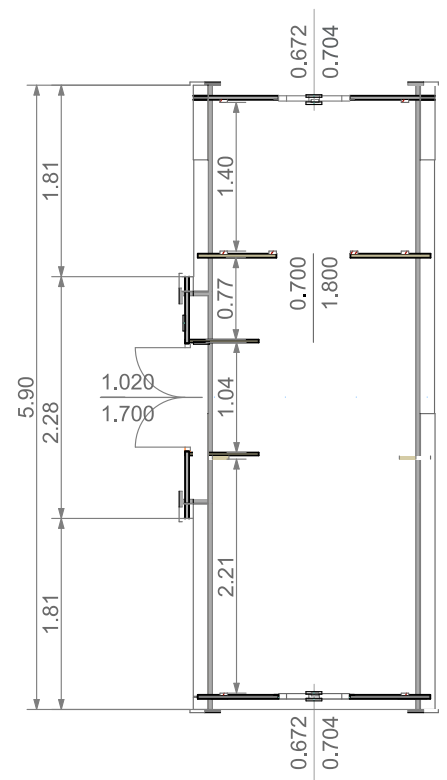

Cut view

This model have more extra usable space because of the stylish side entrance and can be extra fully furnished: single or double beds, a table with poufs, cabins, shelves, and others.

For more information about the furniture please check in accessories section.



The front of Camping Pod 2.4 x 5.9 m with side entrance



Pod with full glass wall available as extra



The interior of Camping Pod 2.4 x 5.9 m



Inside wall diving sleeping and living zones

# CAMPING POD 3.2 x 4.8



## INSULATION

### Wall insulation

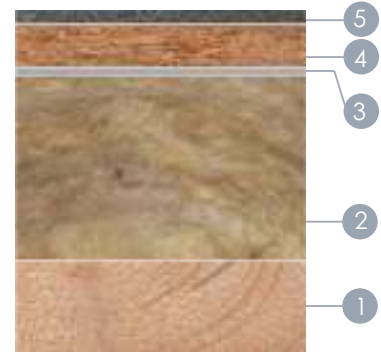

1. Wall made from spruce (38 mm). 2. Stonewool (50 mm). 3. Wind insulating film (1mm). 4. OSB panel (9 mm). 5. Bitumen shingles (3 mm).

### Panel insulation



1. Wall made from spruce (38 mm). 2. Stonewool (50 mm). 3. Wind insulating film (1mm). 4. Wall made from spruce (12 mm) and diffusion film.

### Floor insulation



1. Floor made from spruce (28 mm). 2. Wind insulating film (1mm). 3. Stonewool (50 mm). 4. OSB panel (9 mm) with plastic film.

## INSIDE PLAN

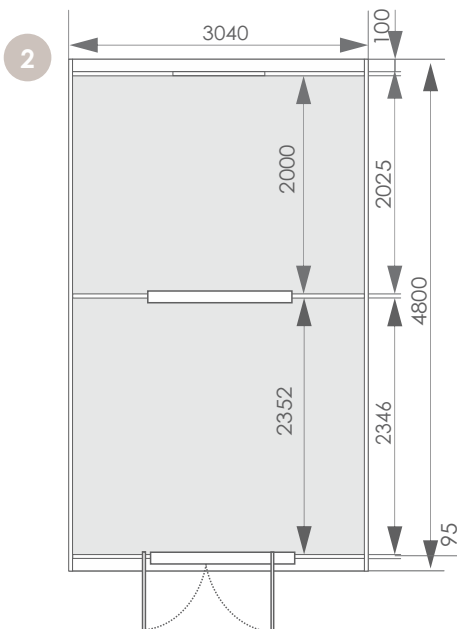
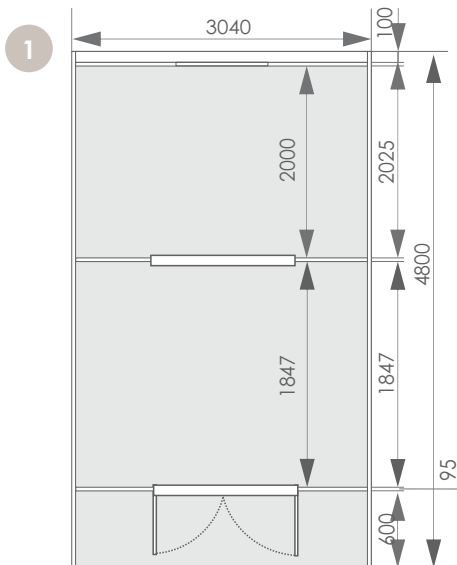

## STANDARD SET

Pod made from spruce with insulated walls;  
Roof covered with bitumen shingles of your selected color;

One opening double window in the back wall;

Double doors with a lock and the double glass windows;

Two rooms inside: sleeping and living room;

Wall partition with the entrance.

## TECHNICAL SPECIFICATION

Shape	Pod
External dimension (W x L)	3040 x 4800 mm
Total high (H)	2560 mm
Inside area	13.4 m <sup>2</sup>
Wall thickness	38 mm
Size of door (W x H)	1020 x 1900 mm
Size of window (W x H)	1010 x 1014 mm
Number of windows	1
Number of opening windows	1
Group of people	4-8 persons
Weight	1800 kg (with furnitures 2650 kg)
Wood	Spruce

## TRANSPORTATION AND ASSEMBLY

The Camping Pod is delivered to a customer **not assembled**, but fully complete, with detailed assembly instructions and drawings, and packed on a pallet (KIT).

Two people can assemble camping pod in 12 hours.

Size of KIT (L x W x H): 4.9 x 1.2 x 2.6 m.

## LAYOUT

1. With terrace 0.6 m: 1st room 1.8 m; 2nd room 2 m length;
2. Without terrace: 1st room 2.3 m and 2nd room 2 m length.

## ROOF COLOR

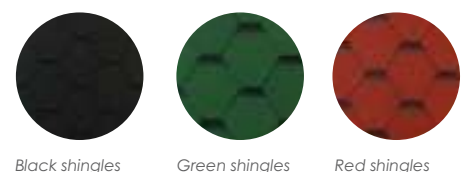



The front of Insulated Camping Pod 3.2 x 4.8 m



The interior of Insulated Camping Pod 3.2 x 4.8 m



# CAMPING POD 3.2 x 5.9



This Insulated Glamping pod 3.2 x 5.9 m is a luxury haven for up to 2-3 people. The layout is done so that you have an intimate and private space for the toilet and shower. Large living space is divided into spaces according to need.

## INSULATION

### Wall insulation

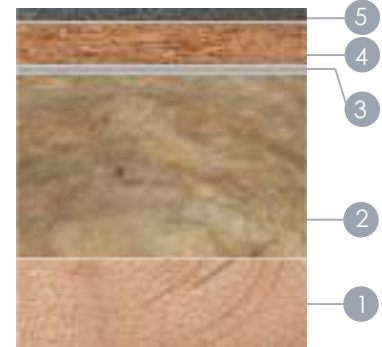

1. Wall made from spruce (38 mm). 2. Stonewool (50 mm). 3. Wind insulating film (1mm). 4. OSB panel (9 mm). 5. Bitumen shingles (3 mm).

### Panel insulation



1. Wall made from spruce (38 mm). 2. Stonewool (50 mm). 3. Wind insulating film (1mm). 4. Wall made from spruce (12 mm).

### Floor insulation



1. Floor made from spruce (28 mm). 2. Wind insulating film (1mm). 3. Stonewool (50 mm). 4. OSB panel (9 mm).

## STANDARD SET

- ..... Pod made from spruce with insulated walls;
- ..... Insulated floor from 28 mm spruce boards;
- ..... Inside wall dividing sleeping and living zones;
- ..... Roof covered with bitumen shingles of your selected color;
- ..... One double opening window in the back wall;
- ..... Two opening windows in the front wall;
- ..... French style double glazed doors with the lock and standard handle in the front;
- ..... Closet or pantry area - 0.39 m<sup>2</sup>;
- ..... Place for mini kitchen and shelves for you things;
- ..... Large living room area for double and single beds;
- ..... WC/shower room.

## TECHNICAL SPECIFICATION

Shape	Pod
External dimension (W x L)	3200 x 5900 mm
Total high (H)	2560 mm
Inside area (total)	15.80 m <sup>2</sup>
Inside area of WC/Shower room	3.04 m <sup>2</sup>
Wall thickness	38 mm
Size of door (W x H)	1020 x 1900 mm
Size of double window (W x H)	680 x 710 mm
Size of front widows (W x H)	375 x 672 mm
Number of windows	3
Number of opening windows	3
Group of people	2-3 persons
Wood	Spruce

## INSIDE PLAN

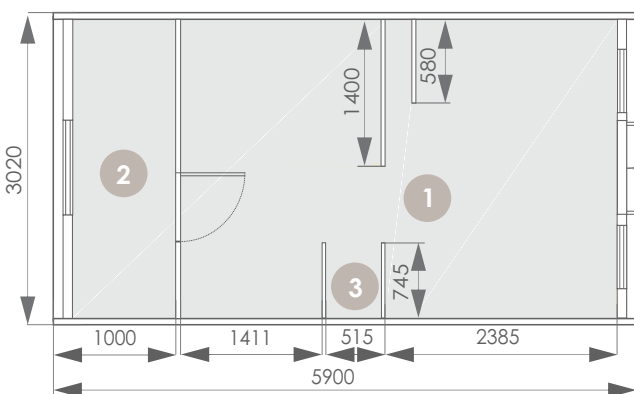

At the entrance, a cozy living area with a seating area. There will definitely fit a comfortable coffee table with puffs, and of course a single bed that can perfectly turn in to the bench. There is also a place for a mini kitchen and a large double bed for your relaxation.

**For more information about the furniture please check in accessories section.**

### LAYOUT

- ..... 1. Living space area: 12.34 m<sup>2</sup>
- ..... 2. Shower and WC room: 3.04 m<sup>2</sup>
- ..... 3. Wardrobe area: 0.39 m<sup>2</sup>

### TRANSPORTATION AND ASSEMBLY

The Camping Pod is delivered to a customer **not-assembled**, but fully complete, with detailed assembly instructions and drawings, and packed on a pallet (KIT). Two people can assemble camping pod in 12 hours.  
**Size of KIT (L x W x H):** 5.9 x 1.2 x 2.6 m.

### ROOF COLOR

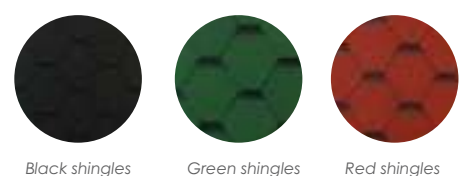



The front of Insulated Camping Pod 3.2 x 5.9 m



The interior of Insulated Camping Pod 3.2 x 5.9 m



Shelves are included in the standard set



Entrance to the WC/shower room





WC room in Insulated Camping Pod 3.2 x 5.9 m



Closet included in standard set of pod. Kitchen set is available as option in Insulated Camping Pod 3.2 x 5.9 m

# HALF PODS

## MODULAR DESIGN

Inspire by you produced by Viking!  
With Half Pod's modular design, you can create a completely customized product to suit your needs and budget!



# HALF POD

2.4 x 2.4  
2.4 x 3  
2.4 x 4  
2.4 x 4.8  
2.4 x 5.9

## MODULAR DESIGN

Can be customized front, back and side walls

Five different sizes

MODULAR DESIGN



Can choose different pod sides: left or right

Can be connected with other half pod

Whether it's a Half Pod with huge double beds and a sauna room or a more basic Pod that offers cozy insurance against bad weather, these sturdy structures are the perfect luxury upgrade. Forget the tent and avoid the hassle with a comfortable Half Pod getaway!

With Half Pod's new design, you can customize each Pod wall to fit your needs and budget!

### STANDARD SET

- Half pod made from spruce wood;
- Roof covered with bitumen shingles of your selected color;
- Left or right side alignment;
- Pod front, back and side walls customization;
- Heat-resistant plates for heater/stove (for pods with sauna room).

### TECHNICAL SPECIFICATION

People	2-4 persons
Timber	Spruce
Shape	Pod
Room	1-2
Total height	2585 mm
Floor thickness	28 mm
Wall thickness	38 mm

### OPTIONS

#### ROOF COLOR

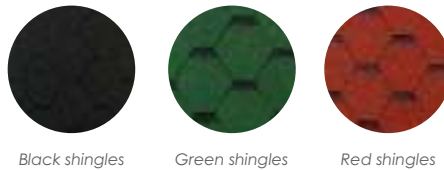

Black shingles

Green shingles

Red shingles

#### MORE OPTIONS

- Different layouts: with or without terrace; one or two rooms inside; empty or with a sauna room
- 5 different sizes: 2.4 x 2.4 m; 2.4 x 3 m; 2.4 x 4 m; 2.4 x 4.8 m; 2.4 x 5.9 m;
- Different Half pod sides: left, right;
- Front/back/side walls modifications: without door and windows; glass door; 2 tempered glass windows for Sauna room;
- Two pods connection: 2 customized Half Pods connected through the side wall;
- Exterior painting.



Available front, back and side walls modifications



Layout: two rooms, without terrace



Interior idea: Shower room

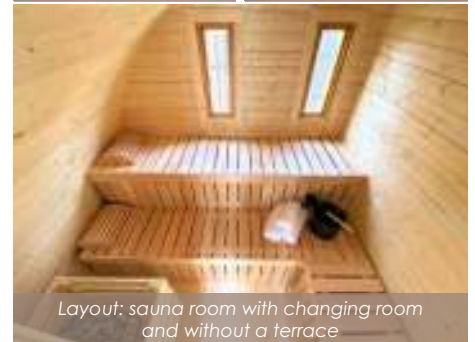

Layout: sauna room with changing room and without a terrace

#### Available different layouts:

1. Empty room without terrace;
2. Empty room with terrace;
3. Two rooms without terrace;
4. Sauna room without terrace;
5. Sauna room with terrace;
6. Sauna room with changing room and without terrace.



1



2



3



4



5



6

# HALF POD

## FRONT / BACK / SIDE WALL

### AVAILABLE DOOR IN FRONT/BACK WALL

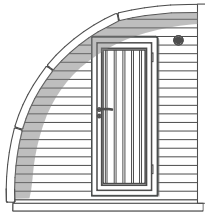

**STANDARD WOODEN DOOR**  
Standard wooden front door (690 x 1850 mm)

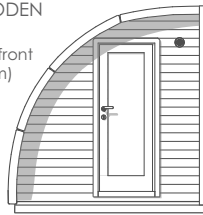

**WOODEN DOOR WITH BIG WINDOW**  
Wooden door (690 x 1800 mm) with brown-toned window

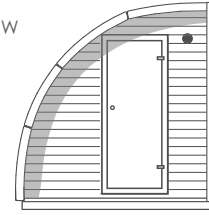

**TEMPERED GLASS DOOR**  
Tempered, brown-toned glass door (690 x 1890 mm)

### AVAILABLE WINDOWS IN FRONT/BACK WALL

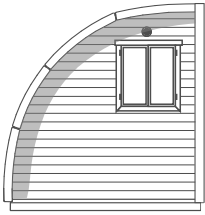

**OPENING WINDOW**  
704 x 672 mm  
Opening window with glass package

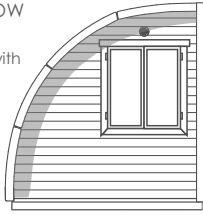

**OPENING WINDOW**  
1014 x 1010 mm  
Opening window with glass package

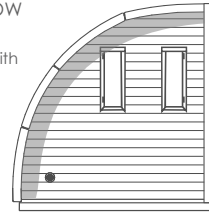

**TEMPERED GLASS WINDOWS FOR SAUNA ROOM**  
750 x 350 mm  
2 pcs of opening and brown-toned windows, suitable for Pods with sauna room  
One window size is 750 x 350 mm

### AVAILABLE EMPTY FRONT/BACK WALL

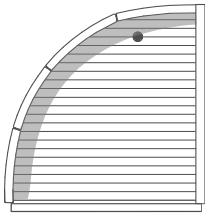

**WITHOUT DOOR AND WINDOWS**

### SIDE WALL AVAILABLE WITH DOOR, WINDOWS OR EMPTY

Side wall modifications available only for Single Pod versions!



### HALF POD MODULAR DESIGN

#### LEFT POD

#### RIGHT POD

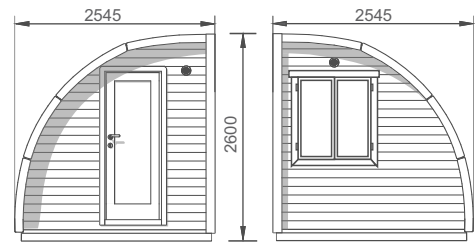

## HALF POD - MODULAR DESIGN

### IDEAS FOR YOUR NEXT PROJECT

Connected two Half Pods:  
Left Side Pod, 2.4 x 4 m size Half Pod with sauna and changing room;  
Right Side Pod 2.4 x 4 m size Half Pod with terrace.

Connected two Half Pods:  
Left Side Pod, 2.4 x 4 m size Half Pod with sauna room;  
Right Side Pod 2.4 x 4 m size Half Pod with terrace.



Inferior idea of what you can create with two Half Pods



With this modular design available to connect two totally customized pods

# OTHER SIZES OF CAMPING PODS

These are several sizes for tiny - one or comfortable two rooms camping pod. We also offered 5 different sizes of camping pods from thermowood. Not all of these camping pods can be delivered to a customer assembled.

## AVAILABLE OTHER SIZES OF CAMPING PODS

Product	Inside area:	Size:	Product package	Standard set:	Timber	Other
<b>Camping Pod 2.4 x 2.4 m</b> <b>NOT INSULATED</b>	5 m <sup>2</sup>	2 people	<b>KIT:</b> 2.5 x 1.2 x 1.25 m <b>Assembled:</b> 2.5 x 2.4 x 2.6 m		Spruce/ Thermowood	<b>Without terrace</b> One room inside
<b>Camping Pod 2.4 x 3 m</b> <b>NOT INSULATED</b>	6 m <sup>2</sup>	2 people	<b>KIT:</b> 3.1 x 1.2 x 1.25 m <b>Assembled:</b> 3.1 x 2.4 x 2.6 m			
<b>Camping Pod 2.4 x 3.5 m</b> <b>NOT INSULATED</b>	7.5 m <sup>2</sup>	2-3 people	<b>KIT:</b> 3.6 x 1.2 x 1.25 m <b>Assembled:</b> 3.6 x 2.4 x 2.6 m	Pod made from spruce; Roof covered with bitumen shingles of your selected color; Opening window in the back wall; Double doors with a lock and the double glass windows; One large room inside.	Spruce/ Thermowood	<b>With or without 0.6 m terrace at the front</b> One room inside
<b>Camping Pod 2.4 x 4 m</b> <b>NOT INSULATED</b>	8 m <sup>2</sup>	2-4 people	<b>KIT:</b> 4.1 x 1.2 x 1.25 m <b>Assembled:</b> 4.1 x 2.4 x 2.6 m			
<b>Camping Pod 2.4 x 4 m</b> <b>INSULATED</b>	8 m <sup>2</sup>	2-4 people <i>comfort sleeping place</i>	<b>KIT:</b> 4.1 x 1.2 x 2.6 m <b>Assembled:</b> 4.1 x 2.4 x 2.6 m	Pod made from spruce; Roof covered with bitumen shingles of your selected color; Opening window in the back wall; Double doors with a lock and the double glass windows; One room inside.	Spruce	<b>With or without 0.6 m terrace at the front</b> One room inside
<b>Camping Pod 2.4 x 5.9 m</b> <b>NOT INSULATED</b>	13.2 m <sup>2</sup>	2-3 people <i>comfort sleeping place</i>	<b>KIT:</b> 5.9 x 1.2 x 2.6 m <b>Assembled:</b> 5.9 x 2.4 x 2.6 m	Pod made from spruce; Roof covered with bitumen shingles of your selected color; Opening window in the back wall; Double doors with a lock and the double glass windows; Two rooms inside: living and shower room.	Spruce/ Thermowood	<b>Without terrace</b> Two rooms inside
<b>Camping Pod 3.2 x 4.8 m</b> <b>NOT INSULATED</b>	13.1 m <sup>2</sup>	2-3 people <i>comfort sleeping place</i>	<b>KIT:</b> 4.9 x 1.2 x 2.6 m	Pod made from spruce; Roof covered shingles of your selected color; Opening window in the back wall; Double doors with a lock and the double glass windows; Two rooms inside.	Spruce/ Thermowood	<b>With or without 0.6 m terrace at the front</b> Two rooms inside
<b>Camping Pod 3.2 x 5.9 m</b> <b>NOT INSULATED</b>	16.3 m <sup>2</sup>	2-3 people <i>comfort sleeping place</i>	<b>KIT:</b> 5.9 x 1.2 x 1.25 m	Pod made from spruce; Roof covered with bitumen shingles of your selected color; Double opening window in the back wall; Double doors with a lock and the double glass windows; Two windows in front wall. Two rooms inside: living and shower room. Mini wardrobe and shelves for things.	Spruce/ Thermowood	<b>Without terrace</b> Two rooms inside

## IMPORTANT

The same size camping pod from spruce or thermowood is the same set and layout.

# SLEEPING BARRELS

## COMFORTABLE OUTDOOR LIVING

Sleeping Barrels are different from the pods in their shape. Barrels are round and looks stylish. Available size from tiny barrel to large sleeping barrel.



# BARREL ICE-VIKING 3 x 4.8



## INSIDE



Sleeping barrel Ice-Viking: sleeping space

## STANDARD SET

- ..... Barrel made from spruce;
- ..... Roof covered with bitumen shingles of your selected color;
- ..... Stainless steel tightening bands;
- ..... One opening window in the back wall;
- ..... Door with a lock and a hexagon glass window;
- ..... Two rooms inside: a sleeping room and a sitting room;
- ..... Available to make sleeping space at sitting room;
- ..... Sleeping room with a sleeping space: 2 x 2.3 m;
- ..... Wall partition with the entrance;
- ..... Small benches at the entrance.

## TECHNICAL SPECIFICATION

Shape	Oval
External dimension (W x L)	4860 x 2952 mm
Total high (H)	2501 mm
Inside area	9.5 m <sup>2</sup>
Wall thickness	38 mm
Size of doors (W x H)	700 x 1725 mm
Number of windows	1
Number of opening windows	1
Group of people	4-8 persons
Weight	1880 kg
Wood	Spruce
Size of terrace (W x D)	2322 x 450 mm

## INSIDE PLAN

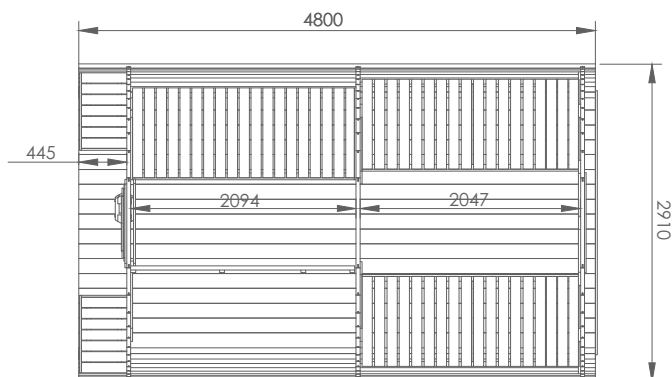

This sleeping barrel has two rooms which you can turn into any space you need. Also available have an area for WC room. Bunk beds are available in the sleeping area.



Sleeping barrel Ice-Viking: living room and WC room



Sleeping barrel Ice-Viking: fragment from the top

### ROOF COLOR



Black shingles



Green shingles

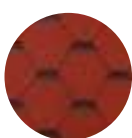

Red shingles

### TRANSPORTATION AND ASSEMBLY

The sleeping barrel Ice-Viking is delivered to a customer **not assembled**, but fully complete, with detailed assembly instructions and drawings, and packed on a pallet (KIT). Two people can assemble Sleeping Barrel Ice - Viking 3x4.8m in 10 hours.

**Size of a KIT (L x W x H):** 4.9 x 1.2 x 2.6 m.

### LAYOUT

**Terrace:** 0.3 m length terrace without benches for 0.45 m length terrace with small benches.

**Slide wall „Ice-Viking“:** wooden slide door with decorative glass.



Possible interior of Barrel Ice-Viking 3 x 4.8 m

# COMMUNITY BARREL Ø2.2 x 4.4



The interior of Community Barrel. Furnitures are included in standard set

Thickness of the barrel walls is 38 mm; thickness of the solid wood flooring is 28 mm. Community barrel is 2.2 m wide and 2.4 m high

## INSIDE PLAN

## STANDARD SET

- Barrel made from spruce;
- Roof covered with bitumen shingles of your selected color;
- Stainless steel tightening bands;
- Four opening windows;
- Doors with a lock and a big windows;
- One room inside with two benches and big table (from laminated plywood);
- Two entrances (in the front and in the back wall).

## TECHNICAL SPECIFICATION

Shape	Round-barrel
External dimension (W x L)	Ø2335 x 4460 mm
Total high (H)	2393 mm
Inside area	9 m <sup>2</sup>
Wall thickness	38 mm
Size of doors (W x H)	700 x 1810 mm
Size of windows (W x H)	380 x 680 mm
Number of windows	4
Number of opening windows	4
Group of people	12-15 persons
Weight	1200 kg
Wood	Spruce

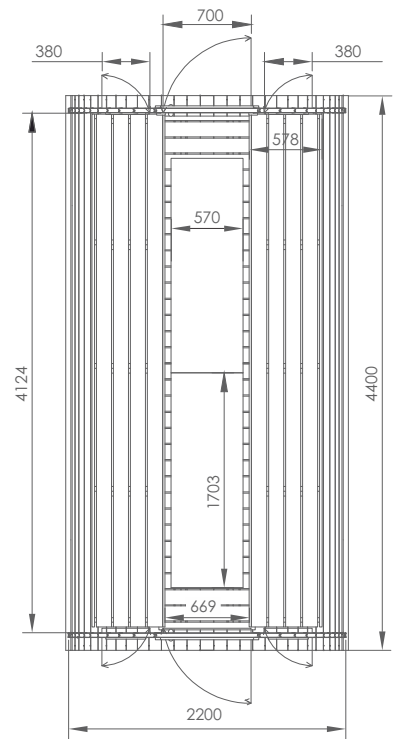
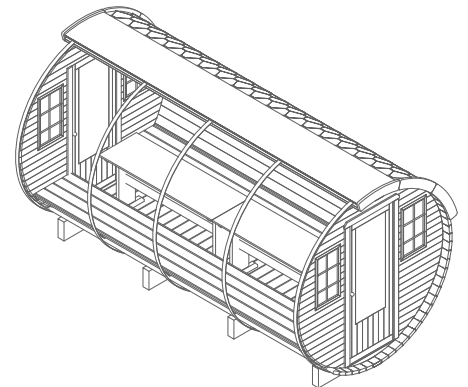

### ROOF COLOR



Black shingles



Green shingles



Red shingles

### TRANSPORTATION AND ASSEMBLY

The Community Barrel is delivered to a customer fully **assembled** or **not-assembled**, but fully complete, with detailed assembly instructions and drawings, and packed on a pallet (KIT). Two people can easily assemble Community Barrel 2.2x4.4 m in 8 hours.

**Size of a assembled cargo (L x W x H):**  
4.5 x 2.32 x 2.4 m.  
**Size of a KIT (L x W x H):** 4.5 x 1.2 x 1.3 m.

### DOOR HANDLE

Wooden knob;

Wooden door handle;

Metal door handle.

*"With this product you can gather all family or friends in one place and not be afraid of bad weather. Imagine rainy day with your friends in Community Barrel playing board games or just catching up with each other!"*

# SLEEPING BARREL Ø2.2 x 3.3

## FAMILY MINI



FURNITURE INCLUDED

This barrel can accommodate two adults and one children



Tiny Sleeping Barrel 2.2 x 3.3 m. Available design with rustic style door and tempered glass window

### STANDARD SET

- Barrel made from spruce;
- Roof covered with bitumen shingles of your selected color;
- Stainless steel tightening bands;
- One opening window in the back wall;
- Two opening windows in front wall;
- Doors with a lock and a double glass window;
- Two rooms inside: a sleeping room and a sitting room; 3 sleeping places;
- Sitting room with two benches and a sliding table;
- Two easily inserted wooden panels between the benches - transform into a single bed;
- Sleeping room with a sleeping space: 2 x 1.68 m;
- All furnitures included in the price.

### TECHNICAL SPECIFICATION

Shape	Barrel
External dimension (W x L)	Ø2240 x 3300 mm
Total high (H)	2394 mm
Inside area	5.4 m <sup>2</sup>
Wall thickness	38 mm
Size of door (W x H)	690 x 1800 mm
Size of front windows (W x H)	380 x 657 mm
Size of back window (W x H)	880 x 510 mm
Number of windows	3
Number of opening windows	3
Group of people	2-3 persons
Weight	900-1000 kg
Wood	Spruce

### INSIDE PLAN

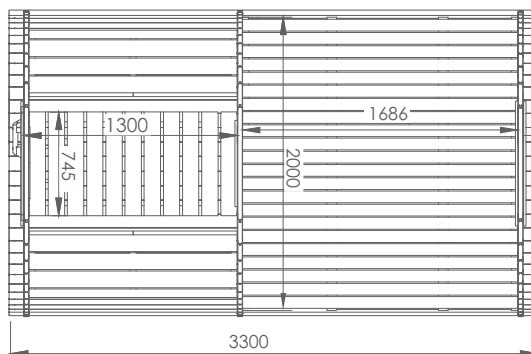

#### ROOF COLOR



Black shingles



Green shingles



Red shingles

#### TRANSPORTATION AND ASSEMBLY

The barrel can be delivered to a customer as fully **assembled** or **not assembled**, with detailed assembly instructions and drawings. It is packed on a pallet (KIT).  
Two people can assemble this barrel within 9 hours.  
**Size of a assembled cargo (L x W x H):** 3.3 x 2.32 x 2.4 m.  
**Size of a KIT (L x W x H):** 3.3 x 1.2 x 1.3 m.



Bespoke project

# SLEEPING BARREL Ø2.2 x 3.3

## WITH BUNK BED



FURNITURE INCLUDED

This barrel can accommodate two adults and 2-3 childrens



Sleeping Barrel 2.2 x 3.3 m with bunk bed. More light inside because of the 2 opening windows in the back wall

### STANDARD SET

- ..... Barrel made from spruce;
- ..... Roof covered with bitumen shingles of your selected color;
- ..... Stainless steel tightening bands;
- ..... Two opening windows in the back wall;
- ..... Two opening windows in front wall;
- ..... Doors with a lock and a double glass window;
- ..... Two rooms inside: a sleeping room and a sitting room; 4-5 sleeping places;
- ..... Sitting room with two benches;
- ..... Sleeping room with a bunk bed;
- ..... All furnitures are included in the price;
- ..... Ventilation.

### TECHNICAL SPECIFICATION

Shape	Barrel
External dimension (W x L)	Ø2240 x 3300 mm
Total high (H)	2394 mm
Inside area	5.4 m <sup>2</sup>
Wall thickness	38 mm
Size of door (W x H)	690 x 1800 mm
Size of front windows (W x H)	380 x 657 mm
Size of back windows (W x H)	880 x 510 mm
Number of windows	4
Number of opening windows	4
Group of people	5-6 persons
Weight	900-1000 kg
Wood	Spruce

### INSIDE PLAN



High between the bunk bed is 824 mm. First floor bed width is 1600 mm and second floor bed width is 2000 mm.

### ROOF

6 layer bitumen tiles consists of durable and highly resistant fiber glass base coated with polymer-reinforced bitumen mix made of high quality bitumen and aggregate. The top layer of tiles is surfaced with mineral granules that lend color to the tiles and ensure high Uvprotection and other weather conditions resistance qualities. The

granules are painted in high temperature using thermal method pigment being burned-in into the surface of granules what guarantees long durability of the color. The bottom of tiles is coated with adhesive polymer-reinforced bitumen layer protected with easily removed silicon membrane.

#### ROOF COLOR



Black shingles



Green shingles



Red shingles

#### TRANSPORTATION AND ASSEMBLY

The barrel can be delivered to a customer as fully **assembled** or **not assembled**, with detailed assembly instructions and drawings. It is packed on a pallet (KIT). Two people can assemble this barrel within 9 hours. **Size of a assembled cargo (L x W x H):** 3.1 x 2.32 x 2.4 m;

**Size of a KIT (L x W x H):** 3.1 x 1.2 x 1.3 m.

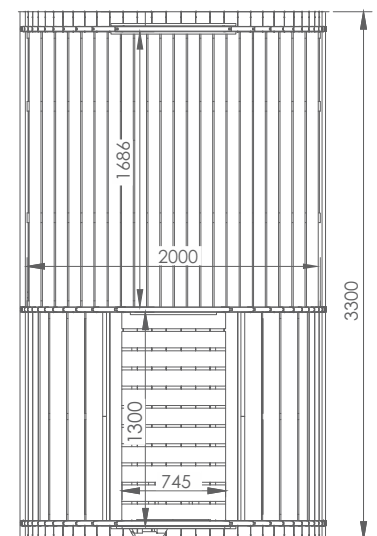

# SLEEPING BARREL Ø2.2 x 4

## CLASSIC



FURNITURE INCLUDED

30 cm wide terrace with two outdoor benches; Locable door with rustic hexagonal window from double glass



Easily inserted wooden panel between the benches - transforms into a single bed

### STANDARD SET

- ..... Barrel made from spruce;
- ..... Roof covered with bitumen shingles of your selected color;
- ..... Stainless steel tightening bands;
- ..... One opening double window in the back wall;
- ..... Door with a lock and a hexagon window;
- ..... Two rooms inside: a sleeping room and a sitting room;
- ..... Sitting room with two benches and a sliding table;
- ..... Available to make sleeping space at sitting room;
- ..... Two easily inserted wooden panels between the benches - transform into a single bed;
- ..... Sleeping room with a sleeping space: 2 x 2 m;
- ..... Small benches at the entrance.

### TECHNICAL SPECIFICATION

Shape	Round barrel
External dimension (W x L)	2236 x 4059 mm
Total high (H)	2394 mm
Inside area	7.3 m <sup>2</sup>
Wall thickness	38 mm
Size of doors (W x H)	690 x 1800 mm
Size of double window (W x H)	715 x 675 mm
Number of windows	1
Number of opening windows	1
Group of people	2-4 persons
Weight	1300 kg
Wood	Spruce

### INSIDE PLAN

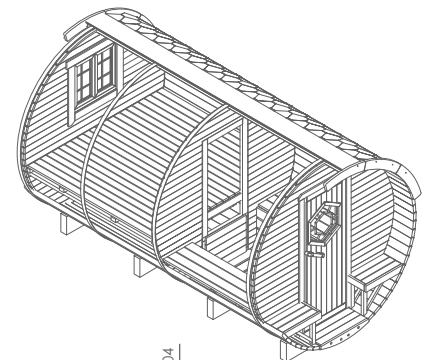

### ROOF

6 layer bitumen tiles consists of durable and highly resistant fiber glass base coated with polymer-reinforced bitumen mix made of high quality bitumen and aggregate. The top layer of tiles is surfaced with mineral granules that lend color to the tiles and ensure high Uvprotection and other weather conditions resistance qualities. The

granules are painted in high temperature using thermal method pigment being burned-in into the surface of granules what guarantees long durability of the color. The bottom of tiles is coated with adhesive polymer-reinforced bitumen layer protected with easily removed silicon membrane.

#### ROOF COLOR



Black shingles



Green shingles



Red shingles

#### TRANSPORTATION AND ASSEMBLY

Sleeping Barrel 4 x 2.2 m is delivered to the customer **assembled** or not **assembled** with detailed assembly instructions and drawings, and packed on a pallet (KIT). Two people can easily assemble Sleeping Barrel 4x2.2m in 10 hours.

**Size of the KIT:** 4.1 x 1.2 x 1.3 m;

**Assembled (L x W x H):** 4.1 x 2.32 x 2.4 m.

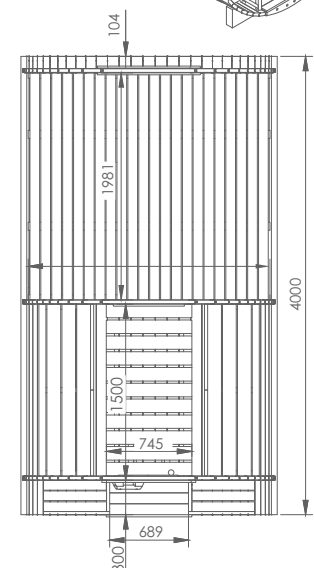

# SLEEPING BARREL Ø2.2 x 4.4

WITH BUNK BED MAXI FAMILY



FURNITURE INCLUDED



Sleeping Barrel 2.2 x 4.4 m with bunk bed. More light inside because of the 2 opening windows in the back wall

## STANDARD SET

- ..... Barrel made from spruce;
- ..... Roof covered with bitumen shingles of your selected color;
- ..... Stainless steel tightening bands;
- ..... Two opening windows in the back wall;
- ..... Two opening windows in front wall;
- ..... Door with a lock and a double glass window;
- ..... Two rooms inside: a sleeping room and a sitting room; 5-6 sleeping places;
- ..... Sitting room with two benches;
- ..... Sleeping room with a bunk bed;
- ..... All furniture included in the price;
- ..... Ventilation.

## TECHNICAL SPECIFICATION

Shape	Barrel
External dimension (W x L)	Ø2245 x 4400 mm
Total high (H)	2394 mm
Inside area	9 m <sup>2</sup>
Wall thickness	38 mm
Size of door (W x H)	710 x 1800 mm
Size of front windows (W x H)	380 x 657 mm
Size of back windows (W x H)	880 x 510 mm
Number of windows	4
Number of opening windows	4
Group of people	4-8 persons
Weight	1400 kg
Wood	Spruce

## INSIDE PLAN



High between the bunk bed is 824 mm. First floor bed width is 1600 mm and second floor bed width is 2000 mm.

## AVAILABLE CLASSIC LAYOUT

Available model also in Classic layout - with one double sleeping bed.

Made from a spruce wood and feels very nature-friendly. Sleeping barrel has two rooms: one is for sleeping and another one for sitting, dining and storing your things. With this barrel your camping place will look different, nature-friendly and cozy.

Two adults and two children can easily fit in our sleeping barrel. The size of sleeping space is 2 x 2 m. The living room is very spacious and has two long benches for it. The size of bench is (D x L) 600 x 2086 mm. There is a sliding table in the sitting room; it can be hidden when it is not needed. The sleeping barrel has one opening window in the back wall and two opening windows in front. The lockable door with a big rectangular window.

### ROOF COLOR



Black shingles



Green shingles



Red shingles

### TRANSPORTATION AND ASSEMBLY

The barrel can be delivered to a customer as fully assembled or not assembled, with detailed assembly instructions and drawings. It is packed on a pallet (KIT).

Two people can assemble this barrel within 9 hours.

**Size of a assembled cargo (L x W x H):**

4.4 x 2.35 x 2.5 m.

**Size of a KIT (L x W x H):** 4.4 x 1.2 x 2.5 m.

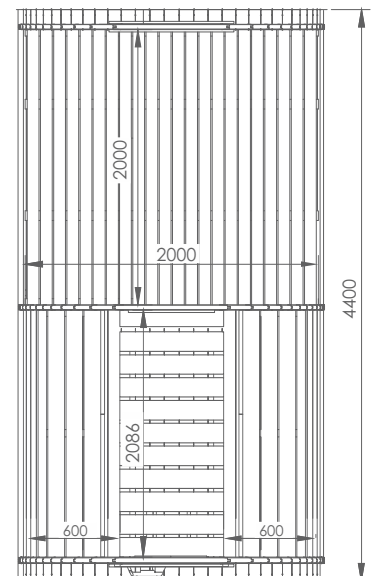

# DELIGHT CAMPING 2.4 x 4.3



TWO ROOMS  
INSIDE



As option you can have free standing furniture and product will be with 2 separate bedrooms

## STANDARD SET

- Delight Camping is made from spruce;
- Roof covered with bitumen shingles of your selected color;
- Stainless steel tightening bands;
- Round window in a back wall;
- Door with a lock and big tempered glass window;
- Two rooms inside: 1st room size is 5.44 m<sup>2</sup>; 2nd room size 3.30 m<sup>2</sup>;
- 2 pcs of ventilation.

## TECHNICAL SPECIFICATION

Shape	Oval
External dimension (W x L)	4290 x 2480 mm
Total high (H)	2500 mm
Inside area	5.6 m <sup>2</sup>
Wall thickness	38 mm
Size of door (W x H)	700 x 1800 mm
Size of back window (W x H)	Ø 850mm
Number of windows (not opening)	1
Group of people	6-8 persons
Weight	1200 kg
Wood	Spruce

## INSIDE VIEW



## PLAN

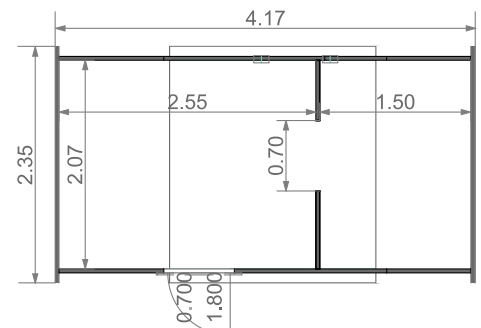
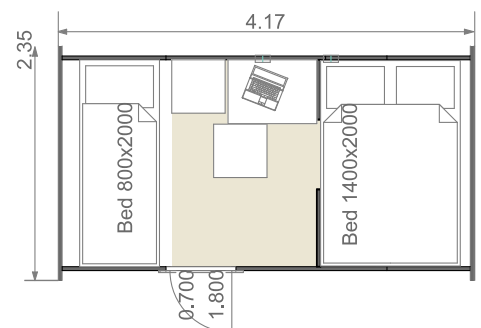

## ROOF COLOR



Black shingles



Green shingles



Red shingles

## TRANSPORTATION AND ASSEMBLY

The product can be delivered to a customer as fully **assembled** or **not assembled**, with detailed assembly instructions and drawings. It is packed on a pallet (KIT). Two people can assemble this product within 15 hours.

**Size of a assembled cargo (L x W x H):** 4.3 x 2.4 x 2.5 m.

**Size of a KIT (L x W x H):** 4.3 x 1.2 x 2.5 m.



# BARREL FOR SLEEPING 2.2 x 5.4

## SIDE ENTRANCE



FURNITURE INCLUDED



### STANDARD SET

- ..... Barrel is made from spruce;
- ..... Roof covered with bitumen shingles of your selected color;
- ..... Stainless steel tightening bands;
- ..... 3 room inside: sleeping, sitting area and WC;
- ..... 2 opening windows in the WC room;
- ..... Double opening window in the sleeping room;
- ..... Wooden door for WC room;
- ..... Side entrance door with a lock and round tempered glass window;
- ..... Double bed of size 1400 x 2000 mm;
- ..... Single bed of size 700 x 2000 mm;
- ..... Small table and bench in sitting area;
- ..... 2 pcs of ventilation;
- ..... One step stair.

### TECHNICAL SPECIFICATION

Shape	Round
External dimension (W x L)	2200 x 5400 mm
Room	3
Diameter	2200 mm
Wall thickness	38 mm
Size of door (W x H)	800 x 1800 mm
Size of window (W x H)	350 x 750 mm 1010 x 1014 mm
Group of people	4-6 persons
Weight	2300 kg
Wood	Spruce

*As option you can order factory painted product!*

### INSIDE VIEW



### PLAN

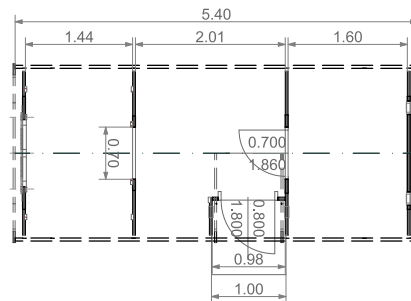
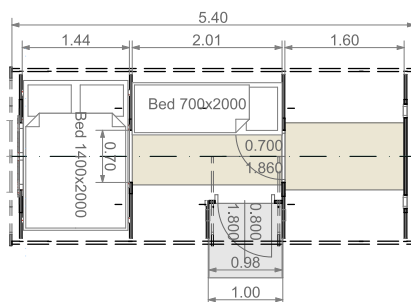

Barrel is equipped with one double bed and one single bed

#### ROOF COLOR



Black shingles



Green shingles

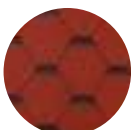

Red shingles

#### TRANSPORTATION AND ASSEMBLY

The barrel with side entrance is delivered to a customer **fully assembled** with using and maintaining instructions.

**Size of a assembled cargo (L x W x H):**  
2.4 x 5.5 x 2.4 m.

# CAMPING CABINS

## STYLISH CAMPING IN RUSTIC

The Camping Cabins in the country style is great for camping, it looks cozy like mountain huts. Possible options: single cabins, double cabins and cabins with extensions. The cabins have from 1 to 3 rooms inside, which can accommodate living, sleeping and shower rooms.



# CAMPING CABIN 9.2

A roof is made of six elements and covered with bitumen shingles

Double glazed windows

Rustic roof porch

The door is decorated with an original hexagonal window

Cabin walls are made of rounded spruce boards

Floor is easily assembled from separate components



Roof window is not opening. The glass is clean and tempered, 8 mm thick

## ROOF

6 layer bitumen tiles consists of durable and highly resistant fiber glass base coated with polymer-reinforced bitumen mix made of high quality bitumen and aggregate. The top layer of tiles is surfaced with mineral granules that lend color to the tiles and ensure high UV-protection and other weather conditions resistance qualities. The granules are painted in high temperature using thermal method pigment being burned-in into the surface of granules what guarantees long

durability of the color. The bottom of tiles is coated with adhesive polymer-reinforced bitumen layer protected with easily removed silicon membrane. As a result of sun heat exposure the overlapped tiles stick to each other thus forming a double hydro-insulating layer, which guarantees excellent leak resistance of the roof. Bitumen tiles can be used both for new construction and roof repair work. You may choose black, green or red color bitumen tiles.

## STANDARD SET

Wall, floor, roof panels from spruce;

Roof covered with bitumen shingles of your selected color;

3 double glass windows (1 of them is opening);

Door with a lock and a hexagon window.

## TECHNICAL SPECIFICATION

Shape	Hexagon – 6 corners
External dimension	4106 x 3556 mm
Total high	3062 mm
Inside area	9.2 m <sup>2</sup>
Size of door (W x H)	780 x 1500 mm
Size of window (W x H)	880 x 510 mm
Group of people	2
Weight	1200 kg
Wood	Spruce
Assembling time	Two people in 6 hours

## PLAN

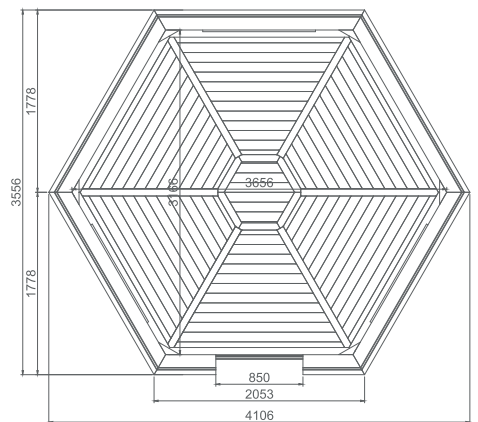

## OPTIONS

**Walls Height:** 1 or 2 extra boards in walls;

**Opening Windows:** 1 from 3 (standard); 2 from 3; 3 from 3;

**Insulated:** roof and floor;

**Available tongue and groove floors;**

**Roof panel with window:** 1-5 pcs.



## ROOF COLOR



Black shingles



Green shingles



Red shingles

## TRANSPORTATION AND ASSEMBLY

Camping Cabin 9.2 m is delivered to the customer fully complete, with detailed assembly instructions and drawings, and packed on a pallet (KIT). Cabin components include six wall panels, six roof panels and three floor panels.

**Cabin 9.2 m<sup>2</sup> pallet size (L x W x H):**  
2.4 x 1.2 x 2.55 m.

# CAMPING CABIN 9.2

## WITH 2 EXTENSIONS

Stylish Rustic-styled entrance to the camping cabin. Door with hexagon double glazed window. The porch above the lockable door

Cabin roof is made of six elements

The size of extension is 4.3 m<sup>2</sup> (L x W - 2.5 x 1.6 m)

Two extensions for your living ideas in rustic style



**THREE ROOMS INSIDE**

Camping cabin walls are made of rounded spruce boards with the dimensions 45 x 145 mm

### OPTIONS

**Walls height:** 1 or 2 extra boards in walls;

**Available insulated roof;**

**Available insulated floor;**

**Available tongue and groove floors;**

**Roof Color**



Black shingles



Green shingles



Red shingles

**Opening windows:** 3 from 5 (standard); 4 from 5; 5 from 5;

**Curtains set:** brown or blue;

**Roof panel with window:** 1-3 pcs.

### STANDARD SET

Wall, floor, roof panels;

Roof covered with bitumen shingles of your selected color;

5 double glass windows (three of them are opening);

Lockable door with double glazing hexagonal window;

3 rooms: 6-corners cabin and 2 rectangular extensions.

### TECHNICAL SPECIFICATION

Shape	Hexagonal + rectangle + rectangle
External dimension (W x D)	8150 x 4430 mm
Total high	3062 mm
Inside area	17.2 m <sup>2</sup>
Size of door (W x H)	780 x 1500 mm
Size of window (W x H)	880 x 510 mm
Number of windows	5
Number of opening windows	3
Available	2-4 persons for comfortable living
Weight	170 kg
Wood	Spruce
The thickness of floor	18 mm
The thickness of walls	45 mm
The thickness of roof	18 mm

### LAYOUT

A tiny and cozy and more spacious camping cabin with two extensions gives substantial space for all your belongings, both on a temporary or a permanent basis.

The cabin with two extensions is a bigger and more spacious structure, thus it offers more liveable spaces that you can use as a storage area.

This cabin are also good sources of campings. Three separate spaces make it possible to arrange the cottage to the living room, bedroom and bathroom spaces.

### TRANSPORTATION AND ASSEMBLY

This camping cabin is delivered to the customer fully complete, with detailed assembly instructions and drawings, and packed on a pallet (KIT).

**Size of the cargo (L x W x H):**  
4.5 x 1.2 x 2.5 m + 2 x 1.2 x 2.5 m.

### INSIDE PLAN

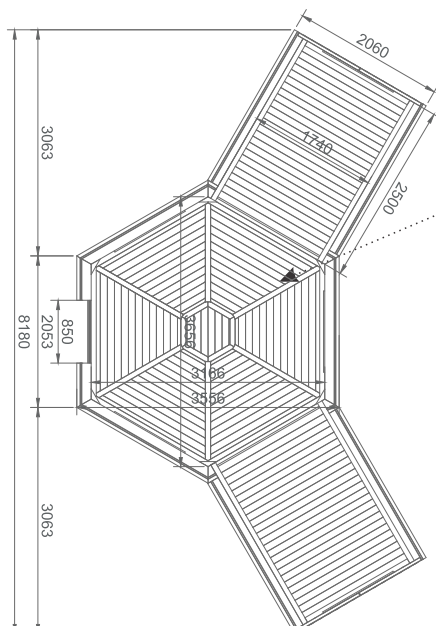

Floor, walls and roof is easily assembled from separate components



This is an example of how the inside of the cabin can be fitted



Interior example of camping cabin 9.2 with 2 extensions

# CAMPING CABIN 14.9

The cabin is lockable, and there is a small porch with a roof at the entrance

Camping Cabin 14.9 m<sup>2</sup> components include eight wall panels, eight roof panels and eight floor panels like in Grill Cabin 16.5 m<sup>2</sup>



Camping Cabin 14.9 project

High-quality materials ensure the longevity of a camping cabin and easy use. Eight cabin walls are made of rounded spruce boards with the dimensions 45 x 145 mm.

## ROOF

6 layer bitumen tiles consists of durable and highly resistant fiber glass base coated with polymer-reinforced bitumen mix made of high quality bitumen and aggregate. The top layer of tiles is surfaced with mineral granules that lend color to the tiles and ensure high UV-protection and other weather conditions resistance qualities. The granules are painted in high temperature using thermal method pigment being burned-in into the surface of granules what guarantees long

durability of the color. The bottom of tiles is coated with adhesive polymer-reinforced bitumen layer protected with easily removed silicon membrane. As a result of sun heat exposure the overlapped tiles stick to each other thus forming a double hydro-insulating layer, which guarantees excellent leak resistance of the roof. Bitumen tiles can be used both for new construction and roof repair work.

## STANDARD SET

Wall, floor, roof panels from spruce;

Roof covered with bitumen shingles of your selected color;

4 double glass windows (2 of them are opening);

Door with a lock and a hexagon window.

## TECHNICAL SPECIFICATION

Shape	Octagonal – 8 corners
External dimension (W x D)	5168 x 4778 mm
Total high (H)	3610 mm
Inside area	14,9 m <sup>2</sup>
Size of door (W x H)	780 x 1500 mm
Size of window (W x H)	875 x 510 mm
Number of windows	4
Number of opening windows	2
Group of people	2 persons
Weight	1600 kg
Wood	Spruce

## INSIDE PLAN

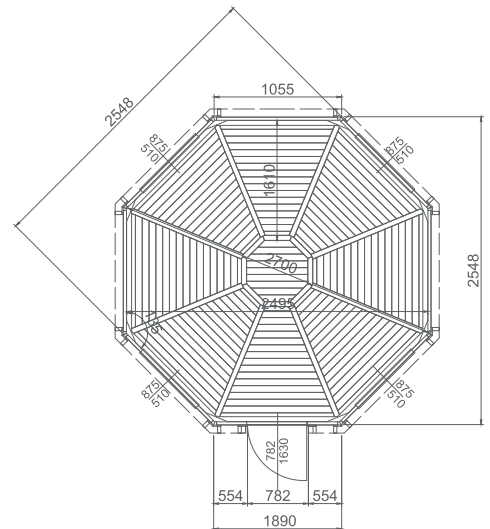

## OPTIONS

**Walls Height:** 1 or 2 extra boards in walls;

**Opening Windows:** 2 from 4 (standard); 3 from 4; 4 from 4;

**Available insulation:** roof and floor;

**Available tongue and groove floors;**

**Curtains Set:** brown or blue;

## ROOF COLOR



Black shingles



Green shingles



Red shingles

## TRANSPORTATION AND ASSEMBLY

This Camping Cabin 14.9 m is delivered to the customer fully complete, with detailed assembly instructions and drawings, and packed on a pallet (KIT).

Two people can easily assemble cabin in 9 hours.

**Size of the cargo (L x W x H):** 3.5 x 1.2 x 2.55 m;

Weight: 1600 kg.

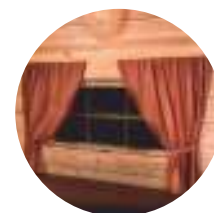

Set of brown

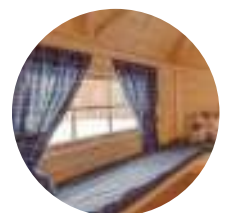

Set of blue

# CAMPING CABIN 16.5 + 16.5

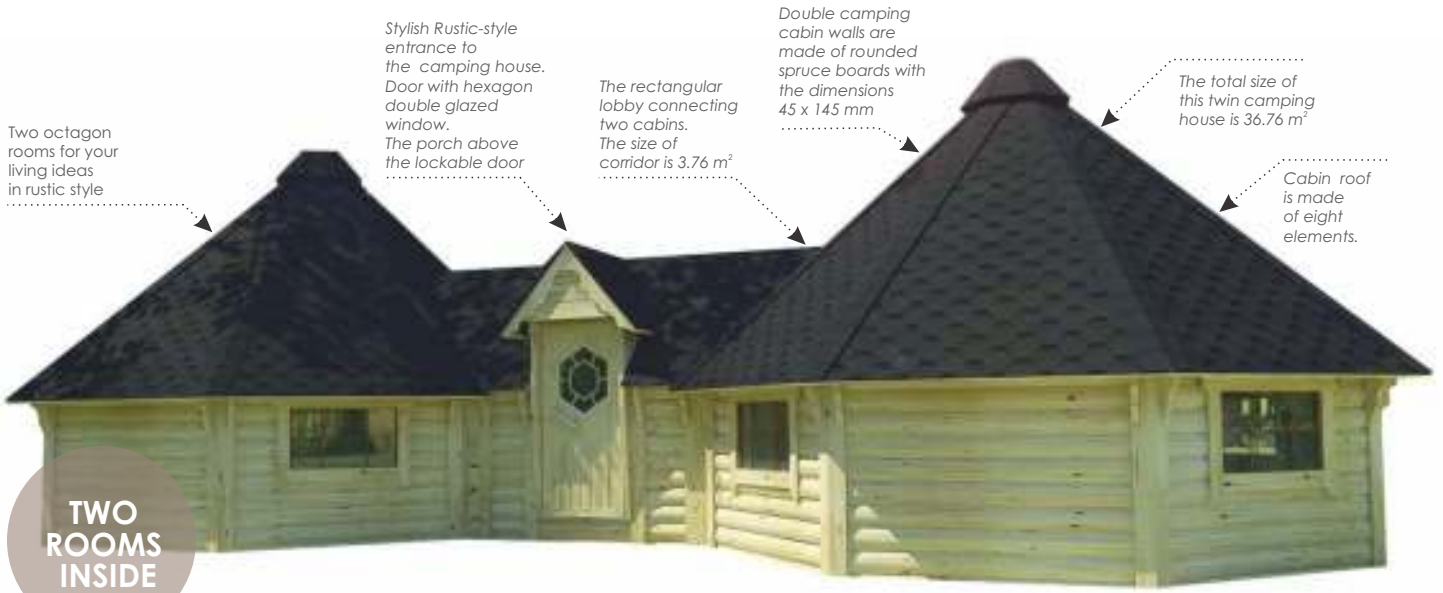

Two octagon rooms for your living ideas in rustic style

Stylish Rustic-style entrance to the camping house. Door with hexagon double glazed window. The porch above the lockable door

The rectangular lobby connecting two cabins. The size of corridor is 3.76 m<sup>2</sup>

Double camping cabin walls are made of rounded spruce boards with the dimensions 45 x 145 mm

The total size of this twin camping house is 36.76 m<sup>2</sup>

Cabin roof is made of eight elements.

**TWO ROOMS INSIDE**

## STANDARD SET

Wall, floor, roof panels from spruce;

Roof covered with bitumen shingles of your selected color;

9 double glass windows (4 of them are opening);

Door with a lock and a hexagon window;

Connection's size: 1.95 x 1.99 m;

Two rooms inside.

## TECHNICAL SPECIFICATION

Shape	Octagonal + rectangle + octagonal
External dimension (W x D)	11899 x 5106 mm
Total high (H)	3446 mm
Inside area	16.5 m <sup>2</sup> + 3.76 m <sup>2</sup> + 16.5 m <sup>2</sup>
Size of door (W x H)	780 x 1500 mm
Size of window (W x H)	880 x 510 mm
Number of windows	9
Number of opening windows	4
Group of people	8 persons
Weight	2650 kg
Wood	Spruce

## OPTIONS

**Walls height:** 1 or 2 extra boards in walls;

**Opening windows:** 4 from 9 (standard); 5 from 9; 6 from 9; 7 from 9; 8 from 9 or 9 opening windows from 9;

**Insulated:** roof and floor;

**Available tongue and groove floors;**

**Curtains set:**

## INSIDE PLAN

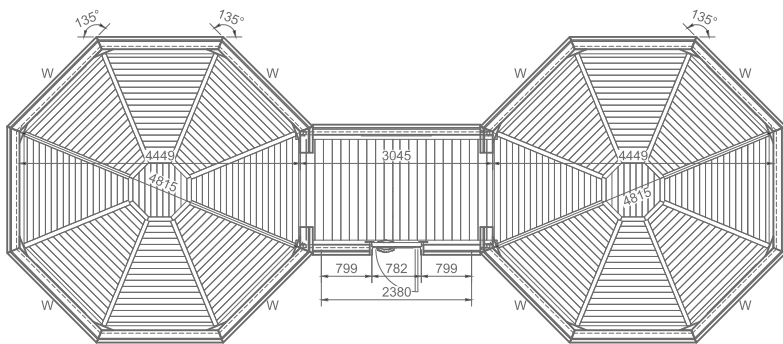

Floor is easily assembled from separate components.



Set of brown



Set of blue

## ROOF COLOR

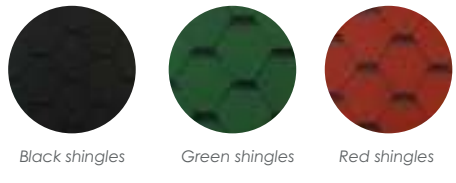

## TRANSPORTATION AND ASSEMBLY

This Camping Cabin is delivered to the customer fully complete, with detailed assembly instructions and drawings, and packed on a pallet (KIT).

Three people can assemble cabin in 14 hours.

**Size of the cargo (L x W x H):** 4 x 1.2 x 2.55 m + 3.5 x 1.2 x 2.55 m.

# CAMPING CABIN 16.5

## WITH 2 EXTENSIONS

Stylish Rustic-stylen entrance to the camping cabin. Door with hexagon double glazed window. The porch above the lockable door

Two extensions for your living ideas in rustic style

Cabin roof is made of eight elements

The size of extension is 4.3 m<sup>2</sup> (L x W - 2.5 x 1.6 m)

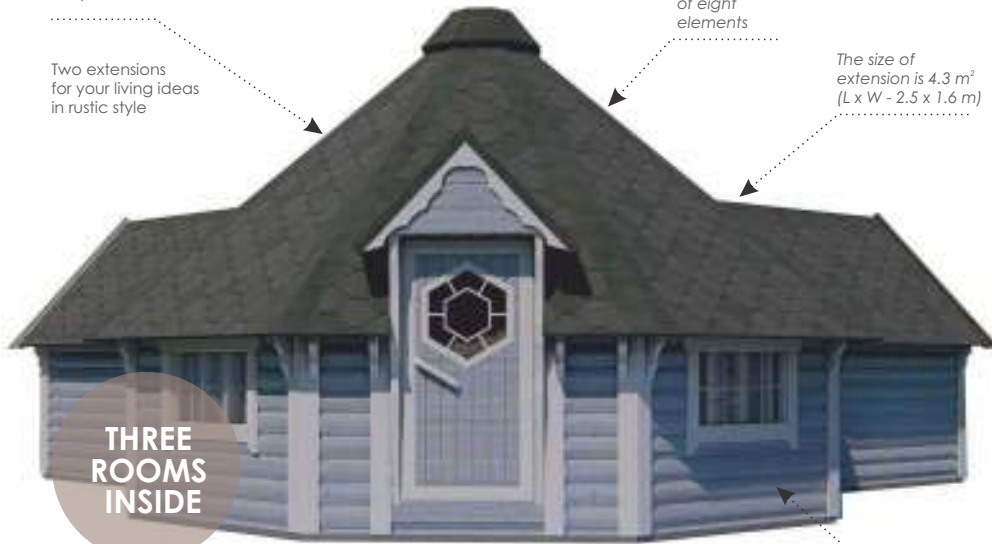

**THREE ROOMS INSIDE**

Camping cabin walls are made of rounded spruce boards with the dimensions 45 x 145 mm

### STANDARD SET

Wall, floor, roof panels;

Roof covered with bitumen shingles of your selected color: red, green, black;

4 double glass windows (all of them are opening);

Lockable door with double glazing hexagonal window;

3 rooms: 8-corners cabin and 2 rectangular extensions.

### INSIDE PLAN

Floor is easily assembled from separate components

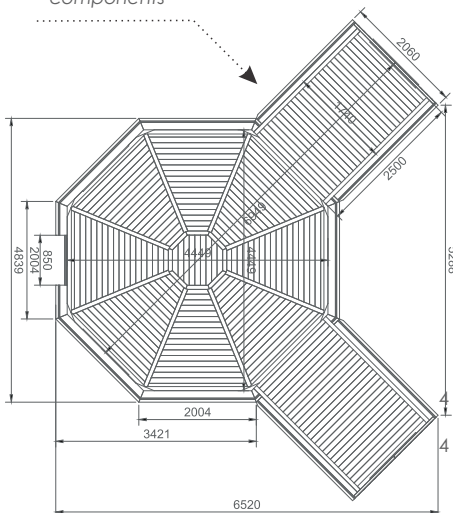

### TECHNICAL SPECIFICATION

Shape	Octagonal + rectangle + rectangle
External dimension (W x D)	8150 x 6240 mm
Total high (H)	3446 mm
Inside area	24.5 m <sup>2</sup>
Size of door (W x H)	780 x 1500 mm
Size of window (W x H)	880 x 510 mm
Number of windows	
Number of opening windows	
Available	5-6 persons for comfortable living
Weight	2500 kg
Wood	Spruce
The thickness of floor	18 mm
The thickness of walls	45 mm
The thickness of roof	18 mm

### LAYOUT

A bigger and more spacious camping cabin gives substantial space for all your belongings, both on a temporary or a permanent basis.

The cabin with two extensions is a bigger and more spacious structure, thus it offers more liveable spaces that you can use as a storage area.

This cabins are also good sources of campings. Three separate spaces make it possible to arrange the cottage to the living room, bedroom and bathroom spaces.

### OPTIONS

Walls height: 1 or 2 extra boards in walls;

Available insulated roof;

Available insulated floor;

Available tongue and groove floors;

Roof Color



Black shingles



Green shingles

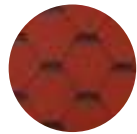

Red shingles

Curtains set: brown or blue;

Roof panel with window: 1-3 pcs.





Interior example of camping cabin  
16.5 with 2 extensions



# EXTENSIONS

3 | 4.3 | 5.2 m<sup>2</sup>

FOR 9.2 m<sup>2</sup>, 16.5 m<sup>2</sup>, 25 m<sup>2</sup> CABINS

# OTHER SIZES OF CAMPING CABINS

## AVAILABLE OTHER SIZES OF CAMPING CABINS

Product	Inside area:		Product package	Standard set:	Timber	Other
Open Camping Cabin 9.2 m <sup>2</sup>	9.2 m <sup>2</sup>	2 - 4 people	KIT: 2.50 x 1.20 x 2.40 m	Wall, roof panels; 6 support wooden columns (SQUARE TYPE); Roof covered with bitumen shingles of your selected color.	Spruce	One room inside
Camping Cabin 9.2 m <sup>2</sup> with extension	12.2 m <sup>2</sup>	2 - 4 people	KIT: 3.80 x 1.20 x 2.55 m	Wooden walls, floors, roof panels; Roof covered with bitumen shingles of your selected color; 4 double glass windows (2 of them are opening); Door with a lock and a hexagon window; Standard extension's size 1.70 x 1.83 m.	Spruce	Two rooms inside 3 different lengths of extensions
Camping Cabin 9.2 m <sup>2</sup> + 9.2 m <sup>2</sup>	22.16 m <sup>2</sup>	6 - 8 people	KIT: 4 x 1.2 x 2.55 m 2.5 x 1.2 x 2.5 m	Wooden walls, floors, roof panels; Roof covered with bitumen shingles of your selected color; 7 double glass windows (2 of them are opening); Door with a lock and a hexagon window; Connection's size 1.95 x 1.99 m.	Spruce	Two rooms inside
Camping Cabin 16.5 m <sup>2</sup>	16.5 m <sup>2</sup>	4 - 6 people	KIT: 3.50 x 1.20 x 2.55 m	Wooden wall, floor and roof panels; Roof covered with bitumen shingles of your selected color; red, green, black; 4 double glass windows (2 of them are opening); Door with a lock and a hexagon window.	Spruce	One room inside
Camping Cabin 16.5 m <sup>2</sup> with extension	19 m <sup>2</sup>	8 - 10 people	KIT: 3.50 x 1.20 x 2.55 m 2 x 1.20 x 2 m	Wooden wall, floor and roof panels; Roof covered with bitumen shingles of your selected color; red, green, black; 5 double glass windows (3 of them are opening); Door with a lock and a hexagon window; Standard extension's size 1.70 x 1.83 m.	Spruce	Two rooms inside 3 different lengths of extensions
Camping Cabin 16.5 + 9.2 m <sup>2</sup>	30 m <sup>2</sup>	8 - 10 people	KIT: 4.60 x 1.20 x 2.55 m 3.50 x 1.20 x 2.55 m	Wall, floor, roof panels; Roof covered with bitumen shingles of your selected color; 8 double glass windows (3 of them are opening); Doors with a lock and a hexagon window; Connection's size: 1.83 x 2.95	Spruce	Two rooms inside
Camping Cabin 25 m <sup>2</sup> with extension	28 m <sup>2</sup>	8 - 10 people	KIT: 4.55 x 1.20 x 2.55 m 2.30 x 1.20 x 2.40 m	Wall, floor, roof panels; Roof covered with bitumen shingles of your selected color; 5 double glass windows (3 of them are opening); Door with a lock and a hexagon window; Standard extension's size: 1.83 x 1.70 m.	Spruce	Two rooms inside 3 different lengths of extensions
Camping Cabin 25 + 25 m <sup>2</sup>	53.8 m <sup>2</sup>	30 - 40 people	KIT: 4.55 x 1.20 x 2.55 m 4.55 x 1.20 x 2.55 m	Wall, roof, floor panels; Roof covered with bitumen shingles of your selected color; 9 double glass windows (4 of them are opening); Door with a lock and a hexagon window; Connection's size: 1.83 x 2.95 m	Spruce	Two rooms inside

# EXTENSIONS 3 | 4.3 | 5.2

## FOR 9.2 m<sup>2</sup>, 16.5 m<sup>2</sup>, 25 m<sup>2</sup> CABINS

Available 3 different sizes of extension for 9.2 m<sup>2</sup>, 16.5 m<sup>2</sup> and 25 m<sup>2</sup> cabins

Two types of extensions: empty or with a sauna room

Extensions with sauna room set:  
Inside partition with tempered glass door  
Heat-resistant plate for the heater/stove  
Sauna benches



### AVAILABLE EXTENSIONS

Ensure that our modular cabins (9.2 m<sup>2</sup>; 16.5 m<sup>2</sup> and 25 m<sup>2</sup>) can meet your needs and wants we suggest choosing the extension from different sizes and types! If you need some extra space you can add an extension of sizes:

**3 m<sup>2</sup> extension (standard size).** Dimensions (L x W x H): 1700 x 1830 x 1155 mm. Empty room.

**4.3 m<sup>2</sup> extension.** Dimensions (L x W x H): 2500 x 1830 x 1155 mm. Empty room.

**4.3 m<sup>2</sup> extension with sauna room.** Dimensions (L x W x H): 2500 x 1830 x 1155 mm. The extension goes together with the inside partition wall (with a glass door between the grill and sauna room), a heat-resistant plate for the heater/stove, and sauna room benches.

**5.2 m<sup>2</sup> extension.** Dimensions (L x W x H): 3000 x 1830 x 1155 mm. Empty room.

3 different lengths:  
1.70 m long extension  
2.50 m long extension  
3 m long extension

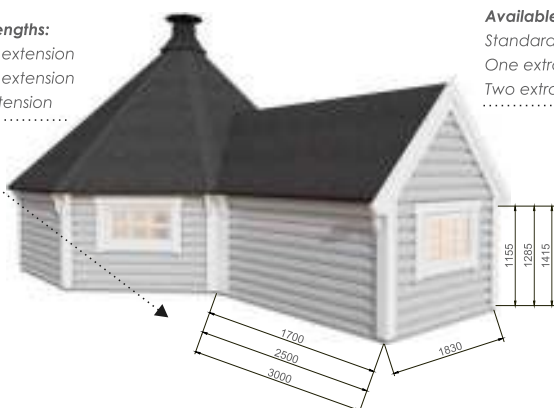

2.5 m long extension two types:  
with or without sauna room

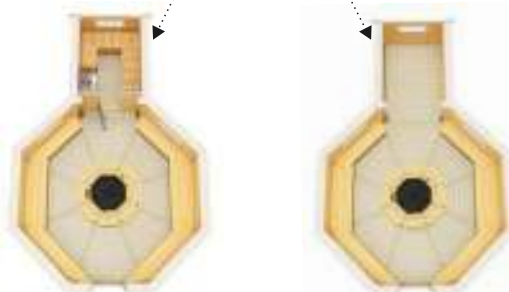

### INTERIOR IDEAS FOR EXTENSIONS



# DOMES

## UPGRADE YOUR SPACE TO NEXT LEVEL

Dome is a new dome tent that's perfect for glamping, camping, or just lounging around in the backyard. It's made from high-quality materials and is weather-resistant so that you can enjoy it all year long.



# DOME 10

Waterproof cover (PVC) with selected color: white or beige

Laminated roof panels (inside) with insulation (as extra)

PVC triangle (with mesh) opening windows (as extra)

Panoramic transparent part cover (PVC)



ONE ROOM INSIDE

## STANDARD SET

- Spruce wood walls and dome frame construction (triangle);
- Weatherproof cover (PVC) with selected color of your choice: white or beige;
- Panoramic transparent part cover (PVC);
- Wooden door with a big window;
- Ventilation.

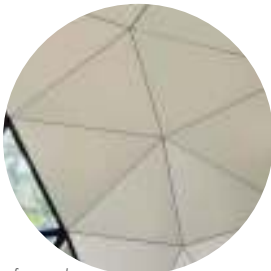

Laminated roof panels (inside) with insulation (as extra)

## INSIDE PLAN

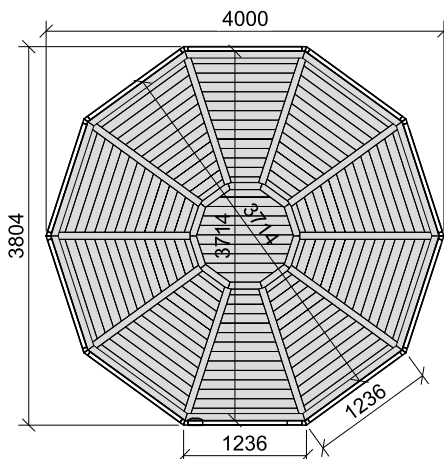

## TECHNICAL SPECIFICATION

Room	1
External dimension (W x D)	3804 x 4000 mm
Total high (H)	2710 mm
Inside area	10 m <sup>2</sup>
Size of door (W x H)	695 x 1800 mm
Wall height	620 mm
Wood	Spruce
The thickness of floor (extra)	18 mm
The thickness of walls	45 mm
The thickness of roof triangles	45 mm

## OPTIONS

Available inside floor;

Inside roof panels. Laminated and insulated;

Terrace floor segments;

Painting. Frame construction (roof part); Walls exterior and interior;

Cover color (PVC): White and transparent; Beige and transparent



White  
RAL9016



Beige  
RAL1013



# VIKING CUBES

## SMART MODULAR SYSTEM

The architectural design of these cubes consists of a modern style with natural wood beauty. The ability to choose large display windows gives you an amazing panoramic view and natural light inside. In the design of these products, we combine traditional materials with state-of-the-art technology to provide comfortable and light-filled spaces. The exterior from spruce wood and the finished coating looks beautiful in their natural environment. Inside there is a wide range of interiors available - there may be everything you want. For one - a relaxing space or a home office; for others, there is a gym, studio, or games room. Each Viking cube is built by an experienced team and the purpose of the cube can be customized to suit your individual needs. All you have to do is decide what you want!



# GLAMPING CUBE 3 x 7

## INSULATED/NOT INSULATED

Living room (3 x 3 m) with two glass walls and aluminum (three rails) sliding system. The room is open, connected to the bedroom

Open bedroom (L x W) - 3 x 3 m with free glass walls panels in the front wall

Glamping cube is connected with two frames: 3 x 3 + 4 x 3 m

Closed shower and WC room (L x W) - 1 x 3 m



### STANDARD SET (INSULATED CUBE)

- .....
- 2 *insulated* frames: 3 x 3 and 4 x 3 m;
- .....
- Aluminum 3 rails sliding door *Raynears*;
- .....
- 5 wooden glass walls with *glass package*;
- .....
- 16 *standard insulated* walls;
- .....
- 1 inner wooden door without window.
- .....

### STANDARD SET (NOT INSULATED CUBE)

- .....
- 2 *not insulated* frames: 3 x 3 and 4 x 3 m;
- .....
- Aluminum 3 rails sliding door *Alutech*;
- .....
- 5 wooden glass walls with *tempered glass*;
- .....
- 16 *standard not insulated* walls;
- .....
- 1 inner wooden door without window.
- .....

### INSIDE PLAN



### TECHNICAL SPECIFICATION

Shape	Rectangle
External dimension (W x L)	3440 x 7570 mm
Total high (H)	2800 mm
Inside area	21 m <sup>2</sup>
Size of inner door (W x H)	819 x 2032 mm
Size of sliding door (W x H)	3000 x 2200 mm
Size of glass wall (W x H)	1000 x 2200 mm
Group of people	2-4 persons
Weight	2800 - 2900 kg
Wood	Spruce
Insulation	50 mm stone wool

#### TRANSPORTATION AND ASSEMBLY

This Glamping Cube is delivered to the customer fully complete, with detailed assembly instructions and drawings, and packed on a pallet (KIT). Two - three people can assemble cabin in 14 hours.

**Size of the cargo (L x W x H):**  
**1st pallet** - 3.4 x 1.2 x 2.6 m;

### FRAME

**INSULATED.** Cube frame from spruce: insulated floor and roof panels, 4 columns. Insulation - stone wool (50 mm). The frames are made from glue laminated spruce beams. Frame consists of bottom frame (100 x 140 mm), columns (140 x 140 mm), top frame (140 x 240 mm) and withstands 442 kg/m<sup>2</sup> roof load. The floor is made of 146 x 28 mm floor board.

**NOT INSULATED.** Cube frame from spruce: floor and roof panels, 4 columns. The frames are made from glue laminated spruce beams. Frame consists of bottom frame (100 x 140 mm), columns (140 x 140 mm), top frame (140 x 240 mm) and withstands 442 kg/m<sup>2</sup> roof load. The floor is made of 146 x 28 mm floor board.

The walls, floor and roof of our glamping Cube are insulated to lower energy costs. We use stone wool to insulate our cubes for this reason: fire resilience, thermal properties, acoustic capabilities, durability, aesthetics, water properties, circularity.

We include all of the screws, nails and fixings needed to put your garden building together. So there's no need to worry about the type of screws, or length of nails etc. You might need to get started, it's all there in the pack!

We are not big fans of OSB sheets as far as floor is concerned. So floor comes with 28 mm wooden boards from spruce.

### SLIDING SYSTEM

#### 3-RAILS SLIDING DOOR REYNAERS.

The size of aluminium 3-rails sliding doors system Reynaers is 3000 x 2200 mm. Standard set: 3 rails; System frame profile wide: 90 mm; Door profile depth of the frame and the sash: 45 mm; Single glass thickness: 4 mm; Colour: metallic/white. This is single-chamber aluminium system.

#### 3-RAILS SLIDING DOOR ALUTECH.

Aluminium 3-rails sliding doors system size is 3000 x 2200 mm. Standard set: 3 rails; System frame profile wide: 90 mm; Door profile depth of the frame and the sash: 45 mm; Single tempered glass thickness is 4 mm; Colour: metallic/white. This is single-chamber aluminium system.

# GLAMPING CUBE 3x8

## WITH SAUNA, GRILLING AND LOUNGE AREA



2 x 3 m cube frame with 2 x 2 m sauna room and 1 x 1 m shower room

Lounge area 3 x 3 m with sunscreen walls

**FOUR SEPARATE AREAS INSIDE**

Garden Cubes project with 6 - corners Grill and Chimney KIT, Fiberglass Hot Tub (as extra)

**Different layouts provide some shade and a spot for your family and friends to create memories!**

### STANDARD SET

- 3 units garden cube frames from spruce
- 3 x 2 m (1 pc) and 3 x 3 m (2 pcs);
- Roof panels with self-adhesive bitumen membrane;
- Insulated roof panels over the sauna room;
- Standard full panel walls;
- Standard insulated full panel walls (inside);
- Wooden tempered glass wall (inside);
- Sunscreen walls;
- Sunscreen walls with glass;
- Insulated wall with small window (180x1200);
- Insulated wall with window (200x200);
- Standard wall with opening window (880x510);
- Full glass wall Alutech 1 m (inside);
- Sliding doors system Alutech 2 m;
- Sliding doors system Alutech 3 m;
- Insulated wall with tempered glass door for sauna room;
- Wall with wooden door for shower room (without window);
- 2 sauna benches from deciduous wood.

### TECHNICAL SPECIFICATION

Rooms	4
External dimension (W x L)	3286 x 8858 mm
Total high (H)	2853 mm
Inside area	24 m <sup>2</sup>
Size of inner door (W x H)	690 x 1850 mm
Size of side sliding doors (W x H)	2000 x 2200 mm
Size of front sliding doors (W x H)	3000 x 2200 mm
Size of glass wall (W x H)	1000 x 2200 mm
Floor thickness	28 mm
Exterior cladding	18 mm
Interior cladding	12 mm
Group of people	5 - 6 persons
Wood	Spruce

This Modern Garden Cubes project consists of 4 spaces inside: a sauna room (2 x 2 m); a shower room (1 x 1 m); grilling area (3 x 3 m); lounge area (3 x 3 m).

### FRAME

The frames are made from glue-laminated spruce beams. The frame consists of a bottom frame (100 x 140 mm), columns (140 x 140 mm), top frame (140 x 200 mm).

### INSIDE PLAN

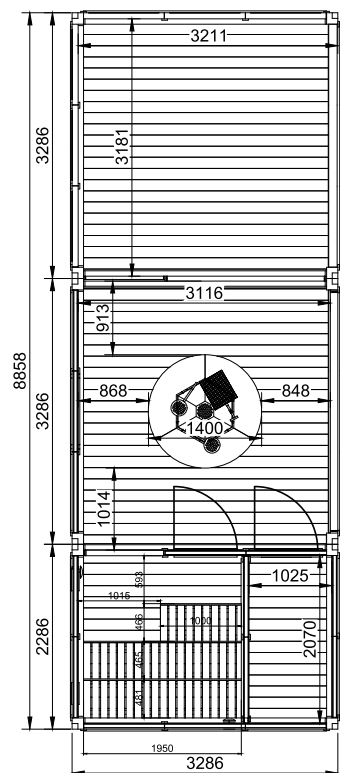

### TRANSPORTATION AND ASSEMBLY

This Garden Cube model is delivered to the customer fully complete, with detailed assembly instructions, drawings and maintenance recommendations, packed on a pallet (KIT). Two - three people can assemble this cube in 56 hours.  
 Size of the cargo (LxW x H):  
 1st pallet - 3.3 x 1.2 x 2.55 m;  
 2nd pallet - 3.4 x 1.2 x 2.55 m.

Cut view

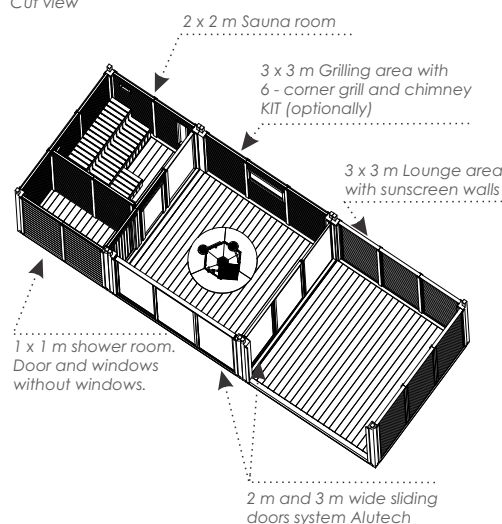



# GLAMPING CUBE 42 | L SHAPE

## INSULATED/NOT INSULATED

Bedroom (3 x 4 m) with two full glass walls and panel with opening window

Shower and WC room - 2 x 3 m

Kitchen and a living room space - 3 x 5 m with Aluminum sliding doors, full glass wall and panel with opening window

Bedroom - 3 x 3 m with full glass walls and panel with opening window



FOUR ROOMS INSIDE

### STANDARD SET (NOT INSULATED CUBE)

- ..... 4 frames: 3 x 3 m (2 pcs) and 3 x 4 m (2 pcs);
- ..... Roof panels with self-adhesive bitumen membrane;
- ..... Wooden floor;
- ..... Standard full panel walls;
- ..... Wooden tempered glass walls;
- ..... Full panel walls with opening windows;
- ..... Wooden doors with a lock (inside);
- ..... Sliding doors system Alutech 3000 x 2200 mm (3 rails);
- ..... 4 rooms inside: 2 bedrooms, shower room and kitchen with living room area.

### STANDARD SET (INSULATED CUBE)

- ..... 4 frames: 3 x 3 m (2 pcs) and 3 x 4 m (2 pcs);
- ..... Roof panels with self-adhesive bitumen membrane;
- ..... Insulated wooden floor;
- ..... Insulated full panel walls;
- ..... Wooden glass walls with glass package;
- ..... Insulated wall panels with opening windows;
- ..... Wooden doors with a lock (inside);
- ..... Sliding doors system Reynaers 3000 x 2200 mm (3 rails);
- ..... 4 rooms inside: 2 bedrooms, shower room and kitchen with living room area.

### Perfect layout for family holidays!

Glamping Cube 42m<sup>2</sup> | Lshape project consists of 4 cube frames: 3x3 m (2 pcs) and 3x4 m (2 pcs).

Using tempered glass walls of size 1000 x 2200 mm to the L-shape project gives a larger feel and also allows natural light to get inside.

This Cube has a 42m<sup>2</sup> plot area and is perfect for 5-6 people. The spaces are defined by two bedrooms 12 m<sup>2</sup> and 9 m<sup>2</sup>, a bathroom 6 m<sup>2</sup>, a kitchen, and a living room space 15 m<sup>2</sup>.

### FRAME

The frames are made from glue-laminated spruce beams. Frame consists of bottom frame (100 x 160 mm), columns (140 x 140 mm), top frame (140 x 200 mm) and withstands 183 kg/m<sup>2</sup> roof load.

### INSIDE PLAN



### TECHNICAL SPECIFICATION

Rooms	4
External dimension (W x L)	6572 x 11858 mm
Total high (H)	2853 mm
Inside area	51 m <sup>2</sup>
Size of inner door (W x H)	690 x 1850 mm
Size of sliding door (W x H)	2000 x 2200 mm
Size of glass wall (W x H)	1000 x 2200 mm
Size of opening window (W x H)	880 x 510 mm
Floor thickness	28 mm
Exterior cladding	18 mm
Interior cladding	12 mm
Group of people	5 - 6 persons
Wood	Spruce
Insulation	50 mm stone wool



### TRANSPORTATION AND ASSEMBLY

This Glamping Cube is delivered to the customer fully complete, with detailed assembly instructions, drawings and maintenance recommendations, packed on a pallet (KIT).

Two - three people can assemble this cube in 56 hours.

Size of the cargo (LxWxH):

1st pallet - 4.4 x 1.2 x 2.6 m

2nd pallet - 3.4 x 1.2 x 2.6 m.



GLAMPING CUBE 51 m<sup>2</sup> | U SHAPE



GLAMPING CUBE 42 m<sup>2</sup> | L SHAPE

# EASY CUBE

For the Viking Easy Cubes have been given special attention to high – speed and easy installation. These compact and bright products are designed as a multi functional space where you can prepare food, spend your leisure. On a warm day, open large doors and enjoy unlimited beautiful weather, on a windy day you can admire the landscape from inside. The style and dimensions of these products fit perfectly into a new residential area, a rural landscape or even a cottage environment.



# EASY CUBE 3 x 3



## ROOF

The roof panels frame 45 x 120 mm is covered with 18 x 145 mm finishing boards. This type of construction withstands 295 kg/m<sup>2</sup> = 2.95 kN/m<sup>2</sup>. Easy Cube building roof is 2.9 m high and 10% slope. We use MIDA SELF KSK for the roof covering,

its self-adhesive elastomeric bitumen membrane covering the entire surface. Installation of the rolled roofing is a quick, simple, and safe way to cover all Cube. All you must do is to unroll, attach with nails, remove protective film and press.

## STANDARD SET

Roof panels from spruce;

Self-adhesive bitumen membrane for roof covering;

Roof, door and windows tin finishing;

Wall panels from spruce with impregnated bottom parts;

2 pcs of aluminum glass wall Alutech (1000x2200 mm);

1 pc aluminum sliding doors system Alutech (3 rails).

## TECHNICAL SPECIFICATION

Shape	4 corners
External dimension (W x L)	3286 x 3155 mm
Total high (H)	2855 mm
Inside area	9 m <sup>2</sup>
Room	1
Size of sliding door (W x H)	3000 x 2200 mm
Size of glass wall (W x H)	1000 x 2200 mm
Group of people	6 persons
Weight	900 kg
Wood	Spruce

### TRANSPORTATION AND ASSEMBLY

Easy Cube is delivered to the customer not assembled (packet n a pallet - KIT), with detailed assembly instructions, drawings and product maintenance recommendations.

**Size of the cargo (L x W x H), not assembled product on pallet ready for transportation:**  
3.40x1.20x 2.50 m.

## FRAME

The cube's solid wooden frame: front and back 45 x 95 mm; sides - 45 x 45 mm with 18 x 145 mm finishing boards make the product a sheltered lounge area. The product has an aluminum glass wall on each side and sliding doors (3 - rails) that can easily be opened in two directions!

## PLAN

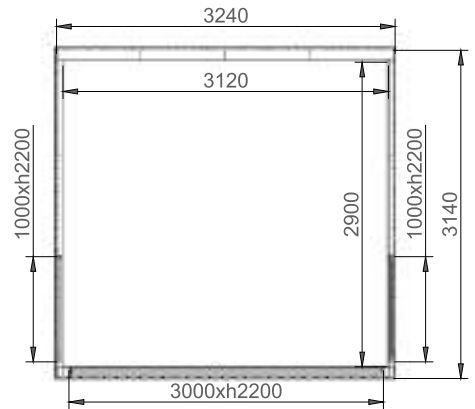

## OPTIONS

### PAINTED PRODUCT

**PROFESSIONALLY SPRAY.** The high-quality preservative finish is professionally spray applied in the factory to three sides of the board. More than 20 different colors, choose from **stains** and **paints!**

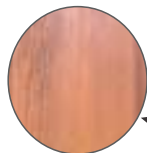

The wood stain treatment shows the wood texture

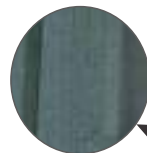

The paint will cover the texture of the wood

### AVAILABLE TO ORDER FLOOR

**Terrace floor.** Made from corrugated spruce wood with frame.

**Tongue and groove floors** (28 mm).



Terrace floor (as option)



Front view



Side and back wall view



Inside view

# EASY CUBE 3 x 3

## WITH 2 x 3 GRILL EXTENSION



WITH  
EXTENSION  
FOR GRILL

The EASY Cube collection is stylish and has a very practical layout. A new two-part model can be a summer kitchen, garden hut, barbeque area, meeting place for young people, or a personal studio where creativity starts to fly. ... It's a multipurpose barrier suitable for both the modern and the traditional houses. The lockable sliding doors of the Easy Cube are integrated into two sides. In good weather, the sliding doors can be opened, and the extension space can be integrated into a unified space.

### WALLS

**Easy cube walls:** Front and back wall frames 45 x 95 mm; Side walls frames 45 x 45 mm; Panels covered with outside 18 x 145 vertical spruce cladding (tongue and groove);

**Extension walls:** Back wall frames 45 x 95 mm; Side wall frames 45 x 45 mm; Horizontal sunscreen walls consists of 45 x 45 mm wood.

### PLAN

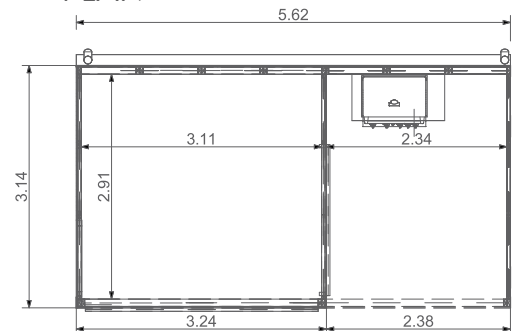

### DRAWINGS

Front view



Back view

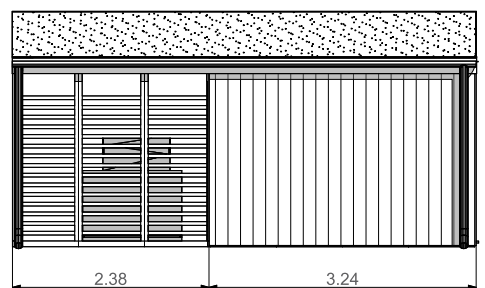

Side view

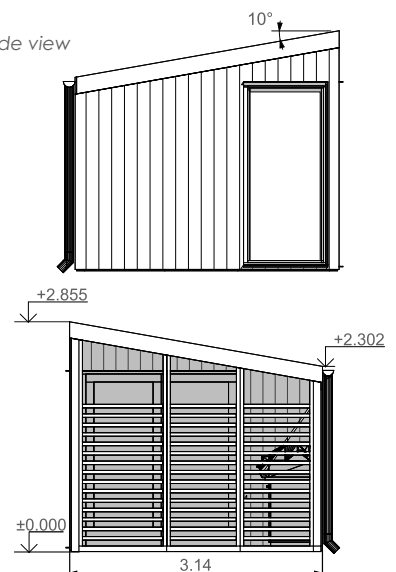

### STANDARD SET

- .....
- Roof panels from spruce;
- .....
- Self-adhesive bitumen membrane for roof covering;
- .....
- Roof, door and windows tin finishing;
- .....
- Wall panels from spruce with impregnated bottom parts;
- .....
- Decorative sunscreen walls with impregnated bottom parts;
- .....
- 1 pc of aluminum glass wall Alutech (1000 x 2200 mm);
- .....
- 2 pc of aluminum sliding doors system Alutech: front 3000 x 2200 mm (3 rails), side 1600 x 2200 mm (2 rails).
- .....

### TECHNICAL SPECIFICATION

Shape	Rectangle
External dimension (W x L)	5620 x 3140 mm
Total high (H)	2855 mm
Inside area	15.85 m <sup>2</sup> (9.05 + 6.79 m <sup>2</sup> )
Room	1
Size of sliding door (W x H)	front 3000 x 2200 mm side 1600 x 2200 mm
Size of glass wall (W x H)	1000 x 2200 mm
Group of people	8 persons
Weight	1100 kg
Wood	Spruce

### OPTIONS

#### PAINTED PRODUCT

**PROFESSIONALLY SPRAY.** The high-quality preservative finish is professionally spray applied in the factory to three sides of the board. More than 20 different colors, choose from **stains and paints!**



The wood stain treatment shows the wood texture



The paint will cover the texture of the wood

#### AVAILABLE TO ORDER FLOOR

**Terrace floor.** Made from corrugated spruce wood with frame;

**Tongue and groove floor (28 mm).**

#### TRANSPORTATION AND ASSEMBLY

Easy Cube is delivered to the customer not assembled (packed on a pallet - KIT), with detailed assembly instructions, drawings and product maintenance recommendations.

Size of the cargo (L x W x H), not assembled product on pallet ready for transportation:

3.40 x 1.20 x 2.50 m.



# OUTDOOR KITCHEN 2.5 x 1.6



MODULAR DESIGN

Outdoor Kitchen. A modular outdoor kitchen for cooking outdoors.

Many of us appreciate being outdoors, so cooking outdoors is one way to maximize our time in the garden. Whether cooking for family, friends, your partner, or yourself, cooking outdoors can help you relax and enjoy your time.

You don't need to live in a mansion to have an outdoor kitchen. All you need is a -backyard!

Our outdoor, backyard kitchen or even you can name it shelter, differs from traditional kitchens because it is modular and you can buy just what you need. Look at the selections below, which range from a simple spice rack to cabinets with LED lighting.

## STANDARD SET

A free-standing modular outdoor kitchen frame, from an anthracite-colored steel (S275). Bottom covered with spruce wood wall 910 mm high.

## TECHNICAL SPECIFICATION

External dimension (W x L)	2536 x 1572 mm
Total high (H)	2388 mm
Group of people	1-2 persons
Weight	600 kg
Wood	Spruce
Pallet size (L x W x H)	0.80 x 1.20 x 2.57 m

## DRAWINGS

Side view



## OPTIONS

### WALL SEGMENTS

- Sunscreen wall segment (445 x 1250 mm);
- Wide sunscreen wall segment (926 x 1250 mm);
- Wall-shelf segment for spices and herbs (from steel) (445 x 1250 mm).

### CABINETS

- Side wall cabinet.** 1-closed wall and open shelves cabinet;
- Back wall cabinet.** Open shelves cabinet.

### LED LIGHTING

- LED lighting.** Warm white LED lighting to the ceiling (on the roof sides) and cabinets (under the worktops).

Back view

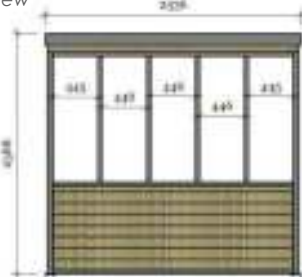

## FRAME

A free-standing modular outdoor kitchen frame, from an anthracite-colored steel (S275).

The bottom is covered with a spruce wood wall 910 mm high.





## AVAILABLE OTHER SIZES OF GLAMPING CUBES

Product	Inside area:	Size:	Product package	Standard set:	Timber	Other
<b>Garden Office 3 x 4 m</b> <b>INSULATED</b>	12 m <sup>2</sup>	2 people	<b>KIT:</b> 4.4 x 1.2 x 2.6 m	Insulated cube frame 3 x 4 m from spruce; Wooden floor (spruce); Roof panels with self-adhesive bitumen membrane; 7 standard insulated panel walls; 2 Wooden glass walls with glass package; 2 sunscreen walls with glass package; Aluminium 3-rails sliding door system with locks „Reynaers“.	Spruce	One room inside
<b>Cube - Hotel 3 x 4 m</b> <b>INSULATED</b>	12 m <sup>2</sup>	2 people	<b>KIT:</b> 4.4 x 1.2 x 2.6 m	Insulated cube frame 3 x 4 m from spruce; Wooden floor (from spruce); Roof panels with self-adhesive bitumen membrane; 7 standard insulated panel walls; 5 wooden glass walls with glass package; Aluminium sliding doors system Reynaers 2 rails.	Spruce	One room inside
<b>Cube - Mans Cave 3 x 4 m</b> <b>INSULATED</b>	12 m <sup>2</sup>	2 people	<b>KIT:</b> 4.4 x 1.2 x 2.6 m	Insulated cube frame 3 x 4 m from spruce; Insulated floor (spruce) and roof panels; Roof panels with self-adhesive bitumen membrane; 11 standard insulated panel walls; 1 decorative sunscreen wall with glass package; Aluminium sliding doors system Reynaers 2 rails.	Spruce	One room inside
<b>Glamping Cube 51   U Shape</b> <b>INSULATED   NOT INSULATED</b>	51 m <sup>2</sup>	2 people	<b>KIT:</b> 4.4 x 1.2 x 2.6 m 3.4 x 1.2 x 2.6 m	Cube frames 3x3 (3 pcs) 3 x 4 m (2 frames) from spruce; Not insulated/Insulated floor (spruce) and roof panels; Roof panels with self-adhesive bitumen membrane; 11 standard not insulated/insulated panel walls; 1 decorative sunscreen wall with tempered glas/glass package; Aluminium sliding doors system Alutech/Reynaers 2 rails.	Spruce	Four rooms inside
<b>Viking Easy Cube 3 x 4 m</b> <b>NOT INSULATED</b>	12 m <sup>2</sup>	8 people	<b>KIT:</b> 3.4 x 1.2 x 2.5 m	Roof panels from spruce; Self-adhesive bitumen membrane for roof covering; Roof, door and windows tin finishing; Wall panels from spruce with impregnated bottom parts; 3 pcs of aluminum glass wall Alutech (1000 x 2200 mm); 1 pc of aluminum sliding doors system Alutech 3000 x 2200 mm (3 rails).	Spruce	One room inside
<b>Viking Easy Cube 3 x 5 m</b> <b>NOT INSULATED</b>	15 m <sup>2</sup>	10 people	<b>KIT:</b> 3.4 x 1.2 x 2.5 m	Roof panels from spruce; Self-adhesive bitumen membrane for roof covering; Roof, door and windows tin finishing; Wall panels from spruce with impregnated bottom parts; 4 pcs of aluminum glass wall Alutech (1000 x 2200 mm); 1 pc of aluminum sliding doors system Alutech 3000 x 2200 mm (3 rails).	Spruce	One room inside
<b>Viking Easy Cube 3 x 3 m with 2 x 3 m Grill Extension</b> <b>NOT INSULATED</b>	15 m <sup>2</sup>	8 people	<b>KIT:</b> 3.4 x 1.2 x 2.5 m	Roof panels from spruce; Self-adhesive bitumen membrane for roof covering; Roof, door and windows tin finishing; Wall panels from spruce with impregnated bottom parts; 4 pcs of aluminum glass wall Alutech (1000 x 2200 mm); 1 pc of aluminum sliding doors system Alutech 3000 x 2200 mm (3 rails).	Spruce	One room inside

### IMPORTANT

Easy Cube models are not modular product as Garden Cubes!

# ACCESSORIES

## CAMPING PRODUCTS



**WOODEN POUF**

The pouf is made of spruce wood, with spacing between the plates, so air circulates easily and ensure good ventilation.



**TABLE**

The table is made of spruce wood. Table has a stable base: the feet are connected additional details. Modern design and the charm of natural wood perfectly complicated camping products.



**DOUBLE BED - SOFA**

The double bed is made of spruce wood. Double bed can be modified into a sofa bed with support. Modern design and the charm of natural wood perfectly complicated camping pods.



**SINGLE BED**

The single bed is made of spruce wood. Bed easily fastened to the wall. Modern design and the charm of natural wood perfectly complicated camping products.

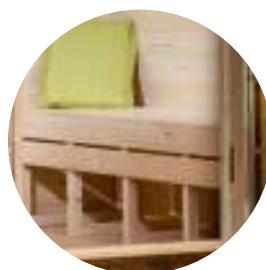

**BENCH**

The bench is made of spruce wood is sturdy and reliable. The bench has the support legs 5, so it is stable. Modern design and the charm of natural wood perfectly complicated camping products.



**CABINET  
2340 x 683 MM**

The cabinet is made of spruce wood is sturdy and reliable. Simple design and the charm of natural wood perfectly complicated camping products. What you get: worktop (from glued wood panels); cabinets, cabinet doors, hinges and knobs. Dimensions (L x W x H): 2340 x 683 x 808 mm.



**DRAWER UNDER THE SINGLE BED**

The drawer is made of spruce wood is sturdy and reliable. Simple design and the charm of natural wood perfectly complicated camping products.



**CABINETS  
1435 x 600 MM  
900 x 600 MM**

Cabinets are made of glued wood panels. Included: frame, table top (from glued wood panels), cabinets with doors, hinges and knobs.



**SHELVE ABOVE DOUBLE  
BED (CLOSED)**

The shelf is made of spruce wood. The shelf is closed with the door from the side of the room. From the inside (from the side of the bed) there is a niche for fitting things.

*Available in Insulated Camping Pod 3.2x5.9m.*

## CAMPING PRODUCTS



### BENCH TRANSFORMING INTO A SINGLE BED

This multi functional piece of furniture provide great seating and sleeping space (bench easy transforms into a bed).



### FLOWER POT "DECOR"

Flower Pot made from 20 segments (each of them is 45x45 mm) to make it look more decorative. Suitable for indoor and outdoor use. This flower pot attractively fit into our modern line Garden cube and all other products.



### CEILING LAMP FOR GLAMPING CUBE

Spruce wood pendant light to light up your Glamping Cube. Size: 1500 x 600 mm.



### TABLE AND BENCHES SET

Modern design spruce wood table and benches set contains:

- Table on wheels (450 x 600 mm);
- Bench (450 x 1400 mm);
- Bench with backrest (800 x 1900 mm).

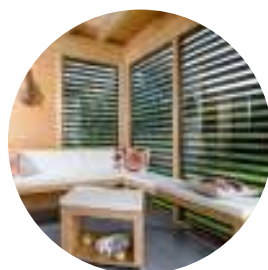

### WHITE CUSHION SET

White imitation leather cushion set designed to fit table and benches set.



### RAINWATER PIPES FOR GLAMPING CUBE

The rainwater pipes package includes straight gutter and all parts needed for installation. Down pipe package includes 2.5 m down pipe and all parts needed for installation. No need for exact measurements and calculations and easy to transport and install, as all components needed are packaged compactly in a single package, ensuring safe delivery and easy installation.

**Rainwater pipes is made of plastic.**  
Color - antracite.



Interior example of camping Pod 2.4 x 4.8 m.

# FACTORY PAINTED CAMPING PRODUCTS

## SPRAY TECHNOLOGY

### Benefits

One of the main and most obvious benefits of using a paint machine is the speed and flexibility at which we can suggest our painting service for all of our products. A spray paint machine can get the work done faster and more consistently than manually painting.

While the machine works faster, it improving quality too – sprayers produce an even coat of paint, leaving a high-quality finish.

With our painting service from now, we can suggest to our client's maximum flexibility! Any size and all types of Camping Products: Camping Pods, Sleeping Barrels, Camping Cabins and Garden Cubes, you can order painted!



## PROFESSIONALLY SPRAY

The high-quality preservative finish is professionally spray applied in the factory to 3 sides of the board. The product is treated in your choice of color.

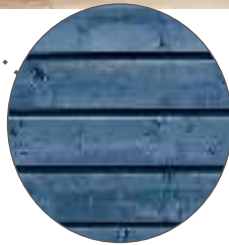

TREATED WITH WOOD STAIN



SCAN ME

## STAIN | PAINT

### Which type of painting should I use?

Properly painting and impregnating is one of the most important things to consider when thinking about how to extend your product lifetime.

Paint and natural wood finish instantly spruce up the aesthetics of your product.

The decision you will need to make is if you want to use a water-based wood stain or paint. Both will offer you UV protection. The wood stains will allow the texture of the wood to show through and many are now available in a vast range of colors, however, paints will give you a intensive color, but will cover the grain and texture of the wood.



The wood stain treatment shows the wood texture



The paint will cover the texture of the wood



REAL PRODUCTS FOR REAL PEOPLE



QUALITY, FLEXIBILITY, SHORT TERMS

[www.vikingindustrier.com](http://www.vikingindustrier.com)

OUR QUALITY STANDARD



Serial No. 2024/02