

# Assembly, installation and maintenance manual

Montage-, Aufbau- und Wartungsanleitung • Assemblage, manuel de montage et d'entretien • Montaje, instalación y mantenimiento • Manuale di montaggio, installazione e manutenzione • Monterings- og vedlikeholdsmanual • Monterings-, installations- och underhållsmanual • Kokoamis-, asennus- ja huolto-ohje • Vejledning for montering og vedligehold • Handleiding voor montage, installatie en onderhoud • Manual de montagem, instalação e manutenção • Návod k montáži, instalaci a údržbě • Instrukcja montażu, instalacji i konserwacji • Surinkimo, montavimo ir priežiūros vadovas • Montāžas, uzstādīšanas un apkopes rokasgrāmata • Руководство по сборке и обслуживанию • Montaaži-, paigaldus- ja säilitamise juhend



## Pavilion **PA44-3535**

<p><b>Factory inspection by</b> • Werkskontrolle durch • Contrôle à partir de l'usine par • Inspector de fábrica • Collaudato da • Fabrikkontroll utført av • Fabriksbesiktigat av • Tehtaan tarkastaja • Fabriks Kontrol udført af • Fabrikscontrole door • Inspeção de fábrica, por: • Zkontrolováno ve výrobním závodě • Kontrola fabryczna do • Apžiūrą gamykloje atliko • Rūpnīcas pārbaudi veicis • Заводской контроль • Tehase kontroll teostatud:</p> <p>.....</p>	<p><b>Date</b> • Datum • Date • Fecha • Data • Dato • Datum • Päiväys • Dato • Datum • Data • Datum • Data • Datums • Data • Дата • Kuupäev:</p> <hr/> <p><b>Pack number</b> • Pack Nr. • Packet n° • Bulto N° • Pacco N. • Serienr • Produktionsnummer • Pakettinro • Pakke nr. • Pak nr. • Número de embalagem • Číslo balení • Numer opakowania • Pakuotės numeris • Iepakojuma numurs • Упаковочный номер • Pakinumber:</p>
--	---



[www.palmako.ee/information-hub](http://www.palmako.ee/information-hub)

**English:** Before installing and using the product, please read the instructions and warranty terms at [www.palmako.ee/information-hub](http://www.palmako.ee/information-hub) to guarantee proper installation and long-lasting performance.

**Deutsch:** Wichtig! Bitte vor Aufbau und Nutzung des Produkts unbedingt die detaillierte Montageanleitung sowie die Garantiebedingungen unter [www.palmako.ee/information-hub](http://www.palmako.ee/information-hub) lesen, um eine fachgerechte Montage und eine lange Funktionssicherheit zu gewährleisten.

**Français:** Avant d'installer et d'utiliser le produit, veuillez lire les instructions et les conditions de garantie sur [www.palmako.ee/information-hub](http://www.palmako.ee/information-hub) afin de garantir une installation correcte et la longévité du produit.

**Español:** Antes de instalar y utilizar el producto, lea las instrucciones y las condiciones de garantía en [www.palmako.ee/information-hub](http://www.palmako.ee/information-hub) para asegurar una instalación correcta y una larga vida útil del producto.

**Italiano:** Prima di installare e utilizzare il prodotto, leggere le istruzioni e le condizioni di garanzia su [www.palmako.ee/information-hub](http://www.palmako.ee/information-hub) per garantire una corretta installazione e prestazioni durature.

**Norsk:** Før montering og bruk av produktet, vennligst les monteringsanvisningene og garantivilkårene på [www.palmako.ee/information-hub](http://www.palmako.ee/information-hub) for å sikre korrekt montering og fremtidig holdbarhet.

**Svenska:** Innan du installerar och använder produkten, vänligen läs instruktionerna och garantivillkoren på [www.palmako.ee/information-hub](http://www.palmako.ee/information-hub) för att säkerställa korrekt installation och produktens långvariga hållbarhet

**Suomi:** Ennen tuotteen asentamista ja käyttämistä, lue ohjeet ja takuehdot osoitteessa [www.palmako.ee/information-hub](http://www.palmako.ee/information-hub) varmistaaksesi oikean asennuksen ja pitkäkestoisen toiminnan.

**Русский:** Перед установкой и использованием изделия ознакомьтесь с инструкцией и условиями гарантии на сайте [www.palmako.ee/information-hub](http://www.palmako.ee/information-hub), чтобы гарантировать правильную установку и долговечность изделия.

**Eesti:** Enne toote paigaldamist ja kasutuselevõttu lugege palun juhiseid ja garantiitingimusi aadressil [www.palmako.ee/information-hub](http://www.palmako.ee/information-hub), et tagada nõuetekohane paigaldus ja toote pikk eluiga.

**Dansk (Oversat af AI):** Læs venligst instruktionerne og garantibetingelserne på [www.palmako.ee/information-hub](http://www.palmako.ee/information-hub), før du installerer og bruger produktet, for at garantere korrekt installation og langvarig ydeevne.

**Dutch (Vertaald door AI):** Lees vóór de installatie en het gebruik van het product de instructies en garantievoorwaarden op [www.palmako.ee/information-hub](http://www.palmako.ee/information-hub) om een correcte installatie en langdurige werking te garanderen

**Português (Traduzido por IA):** Antes de instalar e utilizar o produto, leia as instruções e os termos de garantia em [www.palmako.ee/information-hub](http://www.palmako.ee/information-hub) para garantir uma instalação adequada e um desempenho duradouro.









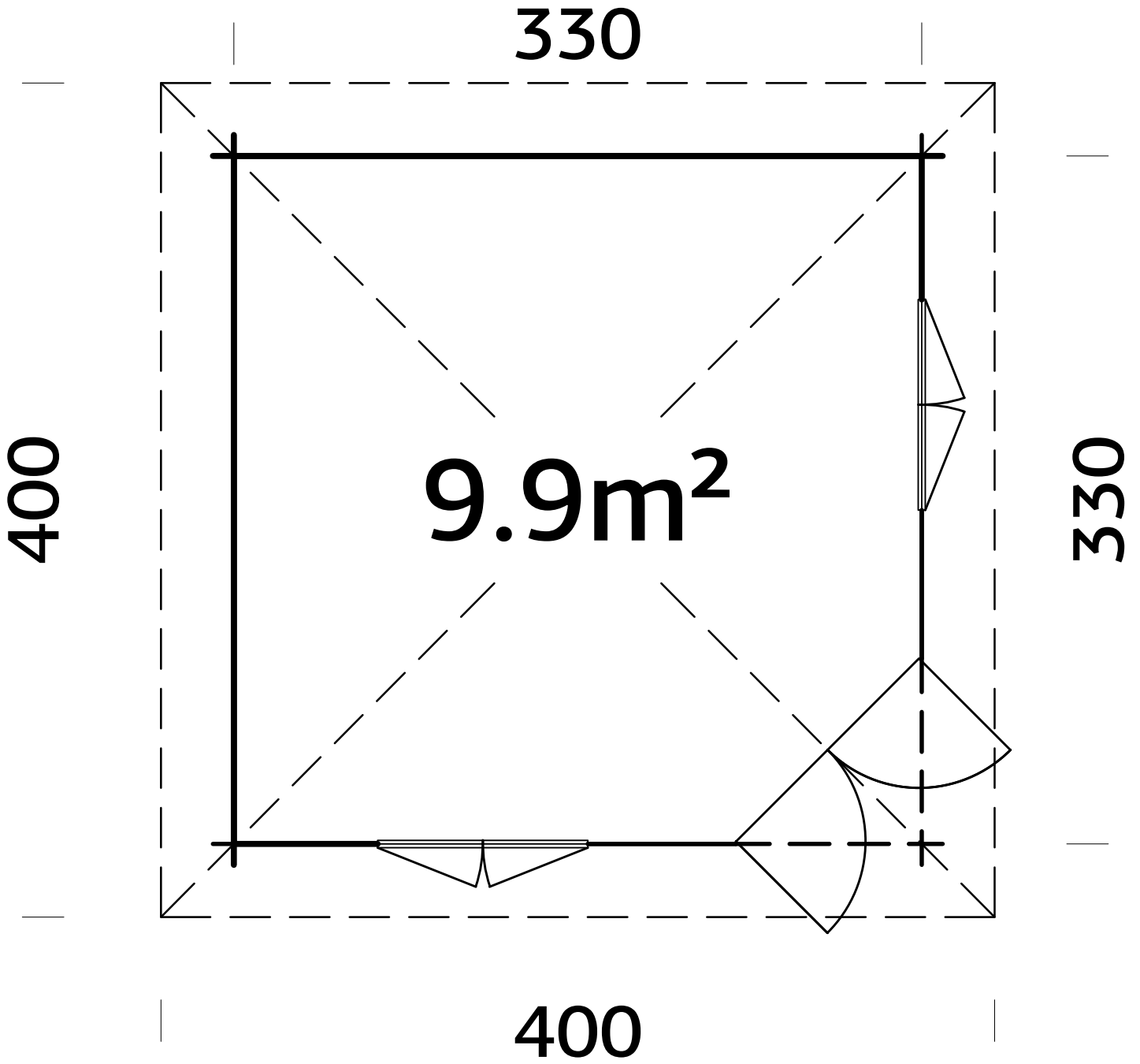

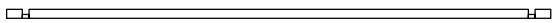

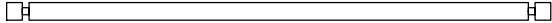

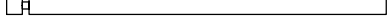

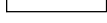



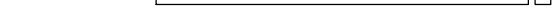

**Čeština (Přeloženo umělou inteligencí):** Před instalací a použitím produktu si prosím přečtěte pokyny a záruční podmínky na [www.palmako.ee/information-hub](http://www.palmako.ee/information-hub), abyste zaručili správnou instalaci a dlouhodobý výkon.

**Polski (Przetłumaczone przez AI):** Przed zainstalowaniem i użyciem produktu należy przeczytać instrukcję oraz warunki gwarancji dostępne na stronie [www.palmako.ee/information-hub](http://www.palmako.ee/information-hub), co pozwoli zagwarantować prawidłową instalację i długotrwałą wydajność.



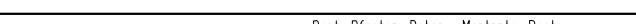

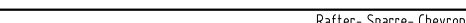





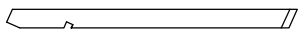
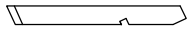
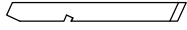





**Latviešu (Mākslīgā intelekta tulkojums):** Pirms produkta uzstādīšanas un lietošanas, lūdzu, izlasiet instrukcijas un garantijas noteikumus vietnē [www.palmako.ee/information-hub](http://www.palmako.ee/information-hub), lai garantētu pareizu uzstādīšanu un ilgstošu darbību.

**Lietuviškai (Išvertė DI):** Prieš montuodami ir naudodami gaminį, perskaitykite instrukcijas ir garantijos sąlygas adresu [www.palmako.ee/information-hub](http://www.palmako.ee/information-hub), kad užtikrintumėte tinkamą montavimą ir ilgalaikį veikimą.

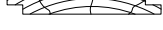
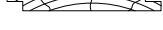
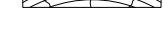
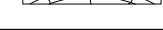
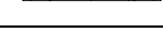
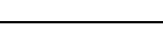



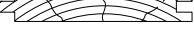

Pos	SPECIFICATION-STÜCKLISTE-NOMENCLATURE-ELEMENTI-ESPECIFICACIÓN PA44-3535	Pcs	Profile (mm)	Length (mm)
001		1	44x57	3500
002		41	44x114	3500
003	 □	2	44x114	3500
004		1	44x57	2443
005		10	44x114	2443
006		23	44x114	790
007		23	44x114	643
008		1	44x114	2538
009		2	44x57	3500
010		1	44x114	2443
011		1	44x114	2538
012		1	44x114	3500
013		1	44x114	1245
014		1	44x57	1245
AR4	Foundation- Fundament- Fondation- Fondazione- Vigas de cimentación 	1	80x60	2866
AR3	Foundation- Fundament- Fondation- Fondazione- Vigas de cimentación 	2	80x60	2390
AR2	Foundation- Fundament- Fondation- Fondazione- Vigas de cimentación 	1	60x80	3230
AR1	Foundation- Fundament- Fondation- Fondazione- Vigas de cimentación 	4	60x80	3170
AR5	Foundation- Fundament- Fondation- Fondazione- Vigas de cimentación 	2	60x80	1273
Det1	Detail- Detail- Detail- Dettaglio- Detalle 	1	70x70	200
EaE1	Eave edging- Dachrandbrett- Madrier en bordure du toit- Tavola bordo tetto- Tabla de valadizo 	4	19x120	4040
Pst2	Post- Pfosten- Poteau- Montante- Poste 	1	90x84	2024
Pst1	Post- Pfosten- Poteau- Montante- Poste 	1	90x84	2024
RoR1	Rafter- Sparre- Chevron- Trave- Cabrio 	4	44x120	2963
RoR4	Rafter- Sparre- Chevron- Trave- Cabrio 	4	44x120	1870



Pos	SPECIFICATION-STÜCKLISTE-NOMENCLATURE-ELEMENTI-ESPECIFICACIÓN PA44-3535		Pcs	Profile (mm)	Length (mm)
RoR2		Rafter- Sparre- Chevron- Trave- Cabrio	4	44x120	1870
RoR5		Rafter- Sparre- Chevron- Trave- Cabrio	4	44x120	1154
RoR3		Rafter- Sparre- Chevron- Trave- Cabrio	4	44x120	1154
SlA1		Slaf- Leiste- Baguette- Listello- Listón	1	19x45	1347
UP3		U-profile board- U-Profilleiste- Baguette profilée en U- Listello profilo ad U- Listón de perfil U	4	70x135	607
UP2		U-profile board- U-Profilleiste- Baguette profilée en U- Listello profilo ad U- Listón de perfil U	4	70x135	607
UP1		U-profile board- U-Profilleiste- Baguette profilée en U- Listello profilo ad U- Listón de perfil U	12	70x135	607
FB2-1	Floor board- Fussbodenbrett- Madrier du plancher - Tavola pavimento- Tabla de suelo- 90°/90°		27	89x19	3205
2FB2-1	Floor board- Fussbodenbrett- Madrier du plancher - Tavola pavimento- Tabla de suelo 2 - 90°/45°		1	89x19	3205
2FB2-2	Floor board- Fussbodenbrett- Madrier du plancher - Tavola pavimento- Tabla de suelo 2 - 90°/45°		1	89x19	3116
2FB2-3	Floor board- Fussbodenbrett- Madrier du plancher - Tavola pavimento- Tabla de suelo 2 - 90°/45°		1	89x19	3027
2FB2-4	Floor board- Fussbodenbrett- Madrier du plancher - Tavola pavimento- Tabla de suelo 2 - 90°/45°		1	89x19	2938
2FB2-5	Floor board- Fussbodenbrett- Madrier du plancher - Tavola pavimento- Tabla de suelo 2 - 90°/45°		1	89x19	2849
2FB2-6	Floor board- Fussbodenbrett- Madrier du plancher - Tavola pavimento- Tabla de suelo 2 - 90°/45°		1	89x19	2760
2FB2-7	Floor board- Fussbodenbrett- Madrier du plancher - Tavola pavimento- Tabla de suelo 2 - 90°/45°		1	89x19	2671
2FB2-8	Floor board- Fussbodenbrett- Madrier du plancher - Tavola pavimento- Tabla de suelo 2 - 90°/45°		1	89x19	2582
2FB2-9	Floor board- Fussbodenbrett- Madrier du plancher - Tavola pavimento- Tabla de suelo 2 - 90°/45°		1	89x19	2493
2FB2-10	Floor board- Fussbodenbrett- Madrier du plancher - Tavola pavimento- Tabla de suelo 2 - 90°/45°		1	89x19	2404
RB5-1	Roof board- Dachbrett- Madrier du toit- Tavola tetto- Tabla de tejado-48°/48°		4	114x19	3991
RB5-2	Roof board- Dachbrett- Madrier du toit- Tavola tetto- Tabla de tejado-48°/48°		4	114x19	3784
RB5-3	Roof board- Dachbrett- Madrier du toit- Tavola tetto- Tabla de tejado-48°/48°		4	114x19	3577
RB5-4	Roof board- Dachbrett- Madrier du toit- Tavola tetto- Tabla de tejado-48°/48°		4	114x19	3369
RB5-5	Roof board- Dachbrett- Madrier du toit- Tavola tetto- Tabla de tejado-48°/48°		4	114x19	3162

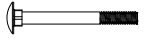
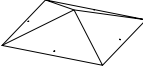



Pos	SPECIFICATION-STÜCKLISTE-NOMENCLATURE-ELEMENTI-ESPECIFICACIÓN PA44-3535	Pcs	
Fim	-Fixing kit- Befestigungsset- Moyens de fixation- Materiale di fissaggio- Kit de fijación	1	USE
QPOYP 8x80Zn	Bolt -Schloss-schraube -Boulon- Bullone- Perno- M8x80mm PUP0	10	SfB1-1
QULSI 30x35	Cylinder- Zylinderschloss- Serrure a mortaiser- Serratura a cilindro- Bombin- 30.35	1	TU44-110P
QLIU KAPal	Door fittings- Türbeschlag- Ferrure- Ferramenta porta- Manilla puerta- QLIUKAPal	1	TU44-110P
QHA1 50Zn	Hook- Haken- Crochet- Ganzio- Pestillo QHA150Zn	2	TU44-110P
QRV1 20Zn	Keeper- Schliessblech- Tole- Lamiera- Aldaba de candado- 120Zn	1	TU44-110P
QNA1 4x40Me	Nail- Nagel- Clou- Chiodo- Clavo- 1.4x40mm	16	FIB2-1; FIB2-2
QNA2 2x50Zn	Nail- Nagel- Clou- Chiodo- Clavo- 2.5x50mm	700	FB2-1; 2FB2-1 RB5-x;
QMUK K8Zn	Nut- Schraubenmutter- Écrou- Dado- Tuerca- M8mm	10	
QK04	Roof cap- Dachkappe- Finition métallique- Finitura di tetto- Caballete de tejado- QK04	1	
QKRPP2 _5x16Zn	Screw- Schraube- Vis- Vite- Tornillo- 2.5x16mm Zn	2	
QKRPP3 _5x40Zn	Screw- Schraube- Vis- Vite- Tornillo- 3.5x40mm	90	UP1; UP2; UP3 EaE1
QKRYP 3x16Zn	Screw- Schraube- Vis- Vite- Tornillo- 3x16mm ZnY	4	
QKRPP 3x20Zn	Screw- Schraube- Vis- Vite- Tornillo- 3x20mm	48	TU44-110P TA44-37P
QKRPP4 _5x70Zn	Screw- Schraube- Vis- Vite- Tornillo- 4.5x70mm	20	001; 004; 009; Rel-1
QKRPP 5x90Zn	Screw- Schraube- Vis- Vite- Tornillo- 5x90mm	110	RoRx; Pstx; 013; 014 TU44-110P
QKRPP6 x120Zn	Screw- Schraube- Vis- Vite- Tornillo- 6x120mm	15	ARx
QSE8 x22Zn	Washer- Dichtscheibe- Joint- Rondella- Arandela- 8x22mm	10	
QLIA	Window fittings- Fenstergriff- Poigne de la fenêtre- Maniglia finestra- Manilla (ventana)	4	TA44-37P
QFK2 40Zn	Window stop- Fensterfeststelle- Crémaillere- Fissativo finestra- Fijador de ventana- QFK240Zn	4	TA44-37P
	Object name PA44-3535		Page 4/5



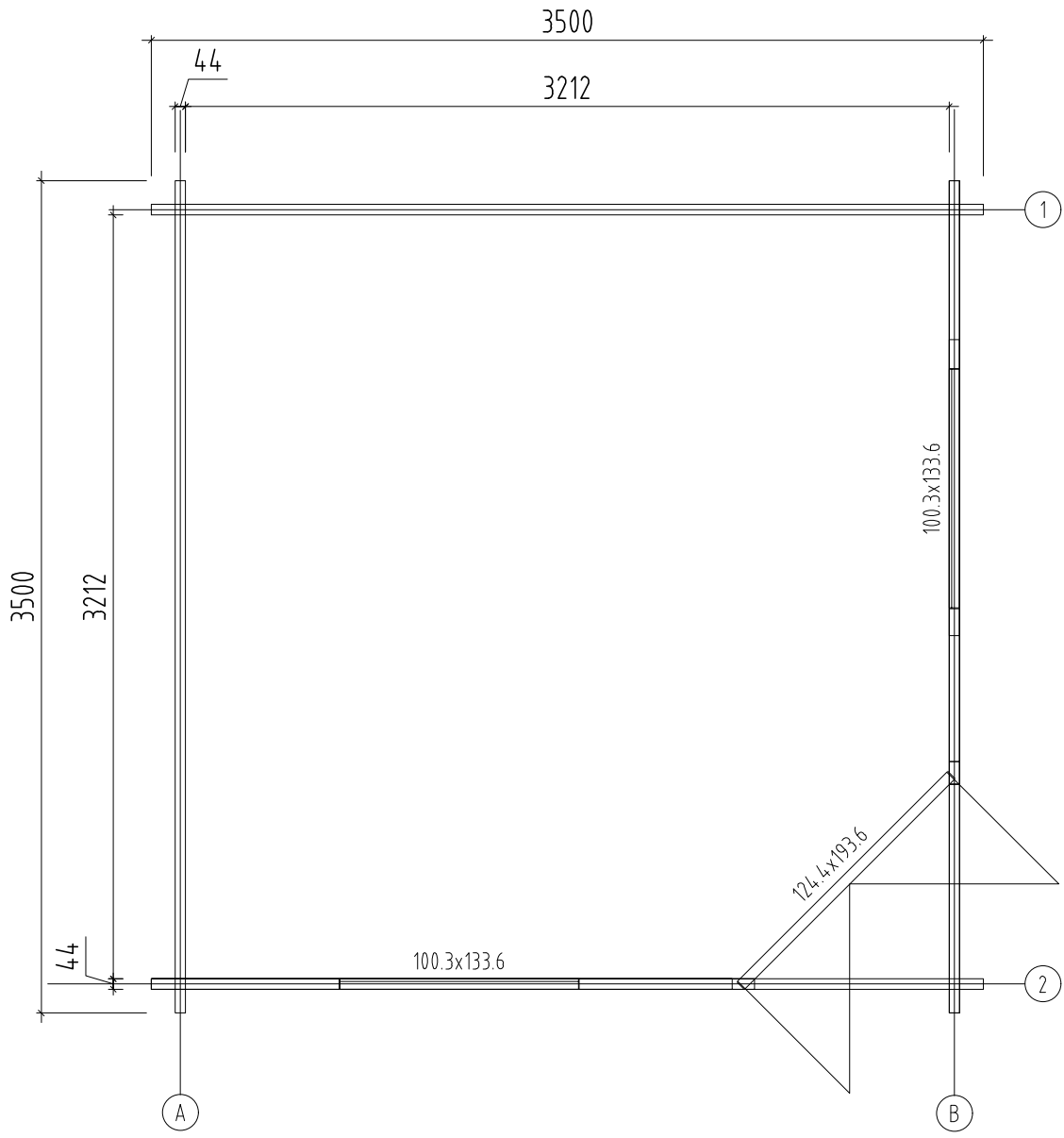

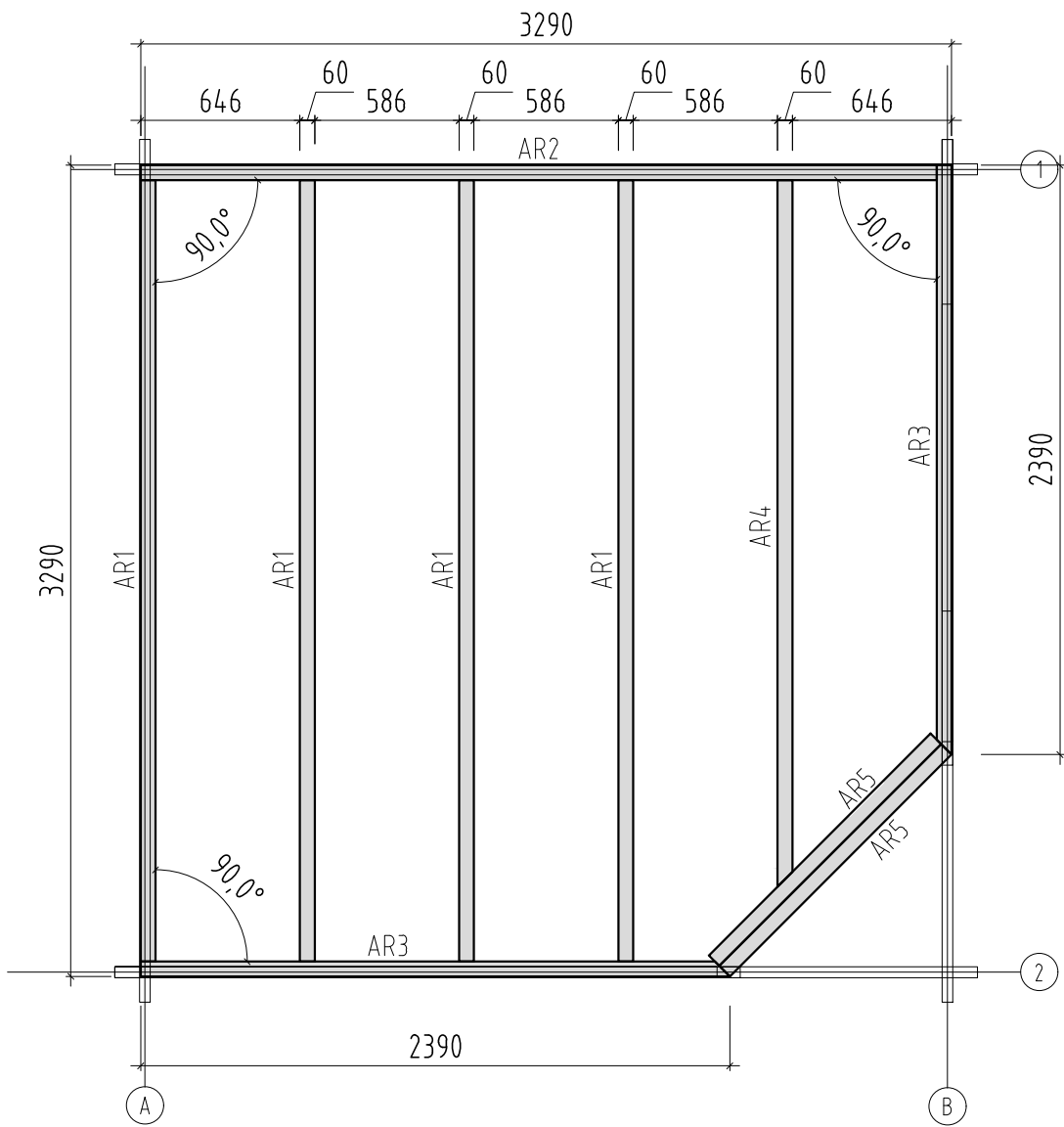

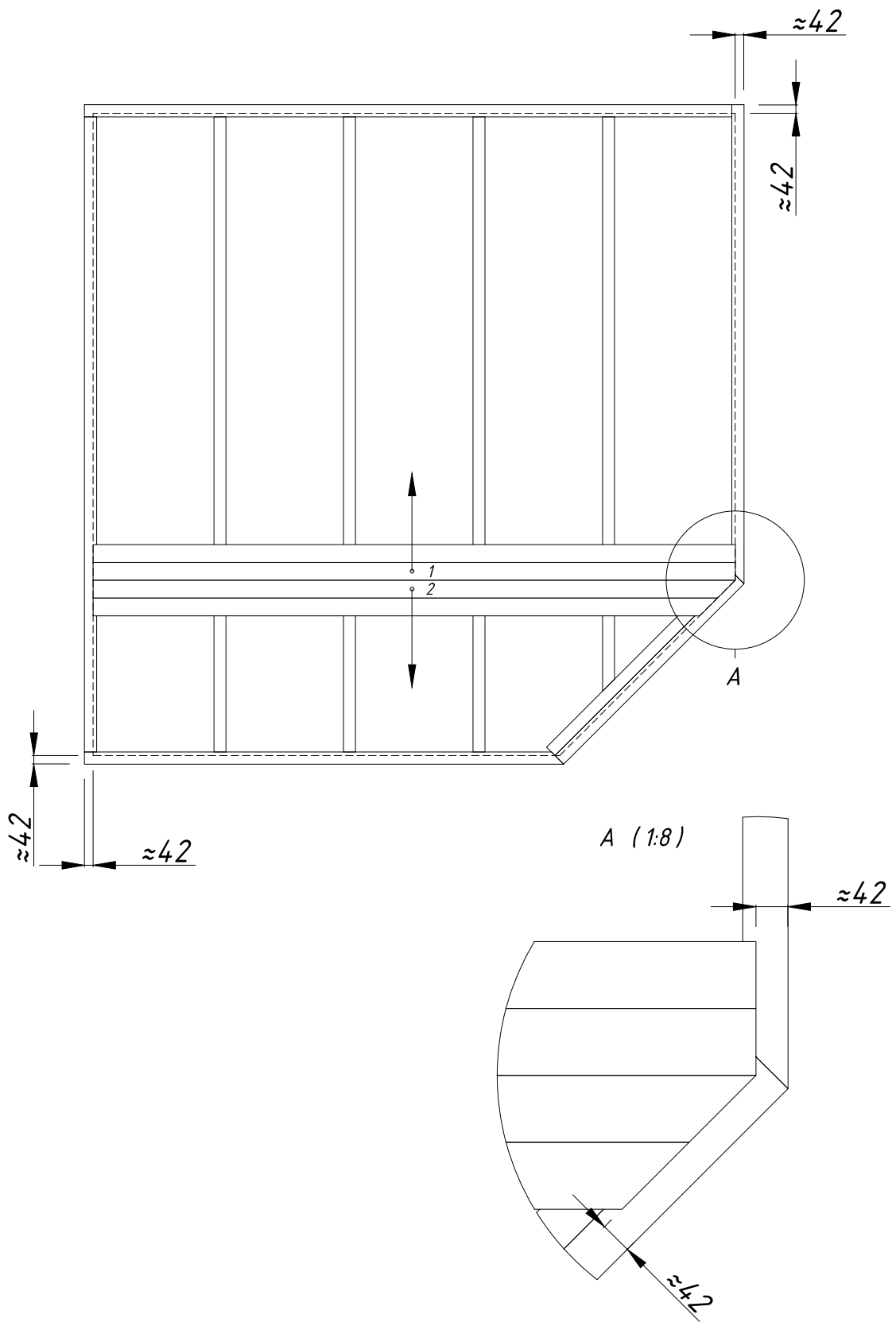

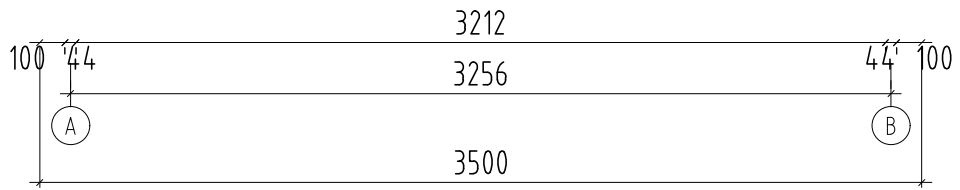





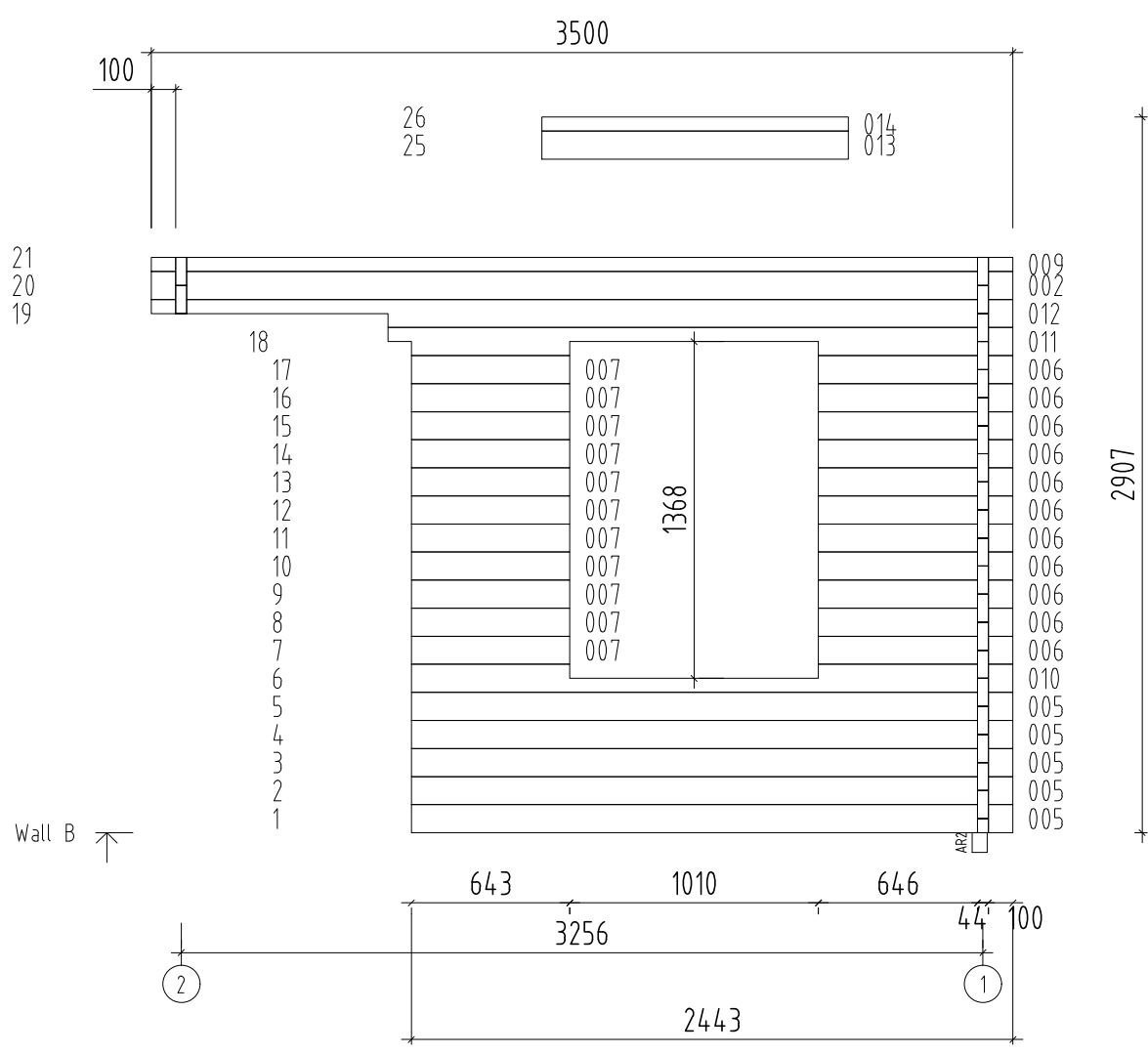

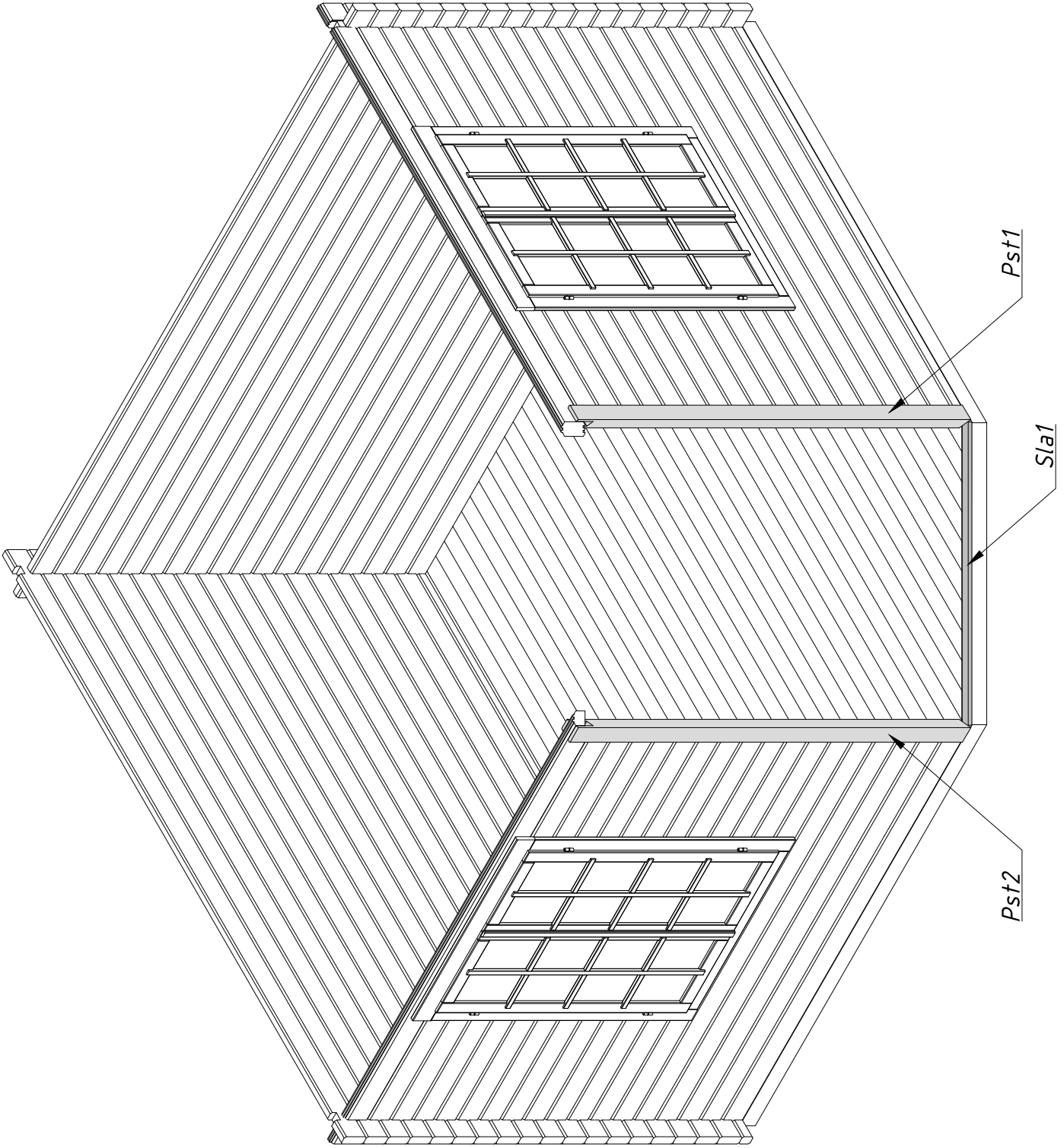

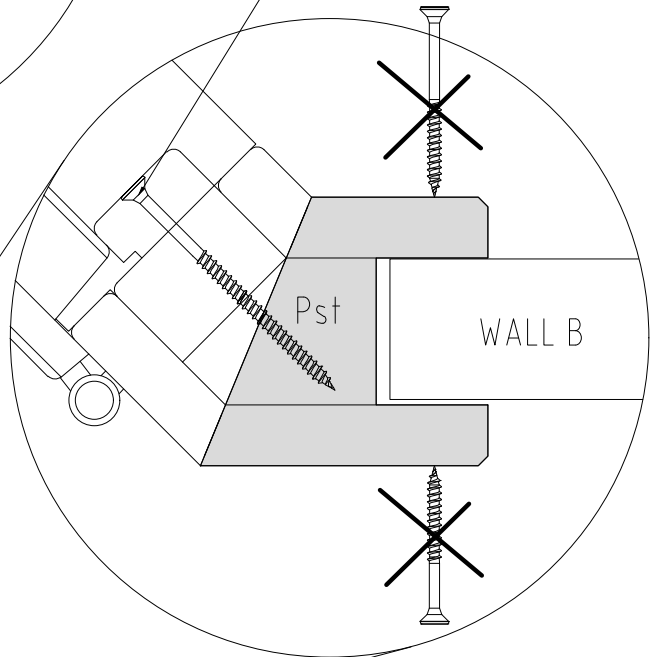
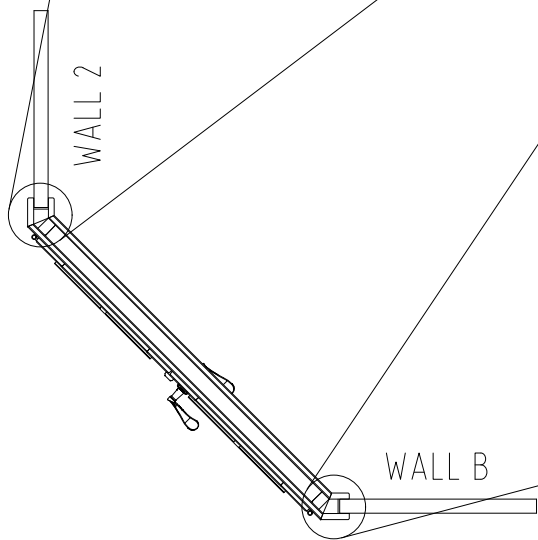
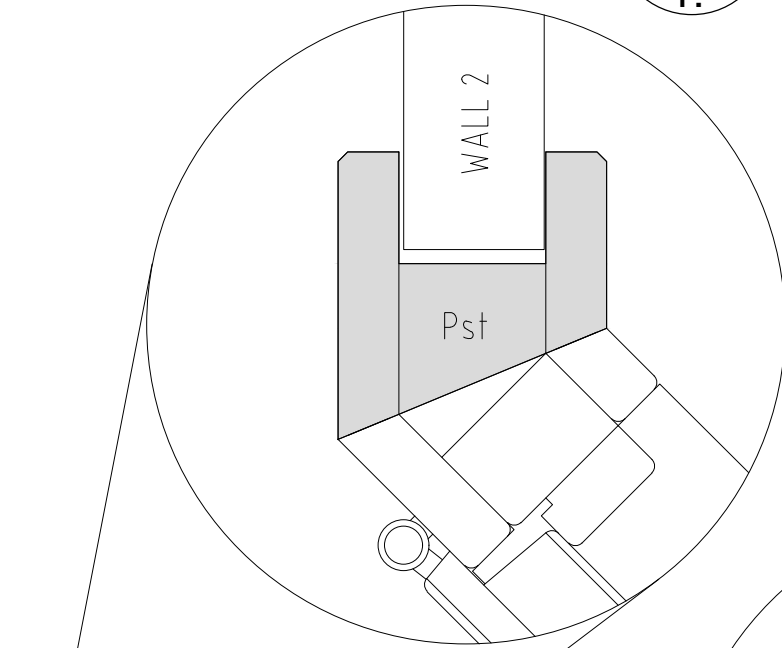
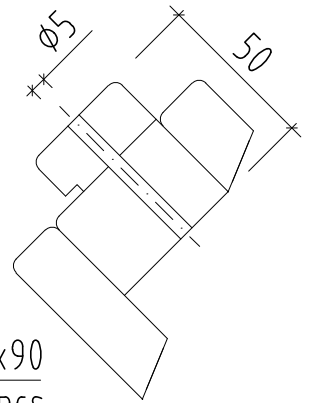
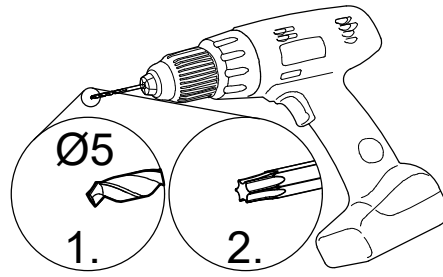

$\varnothing 5 \times 90$   
4 pcs

A:A

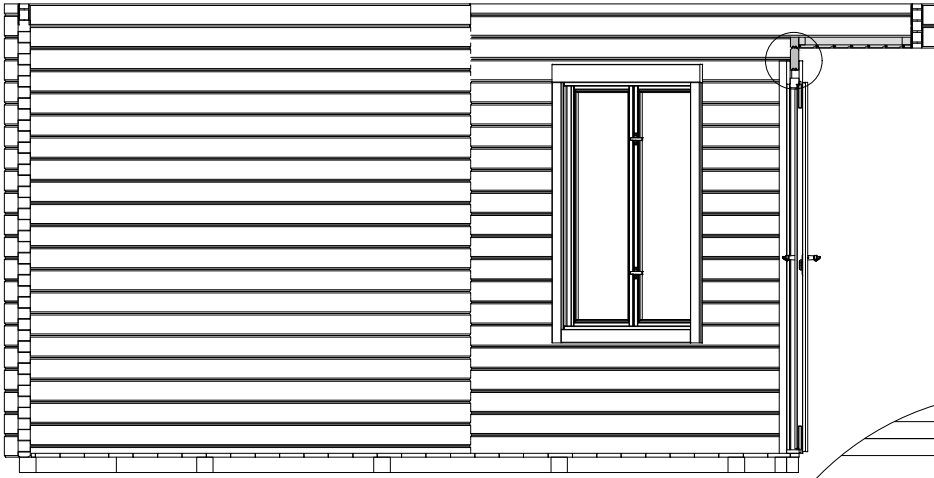

$\phi 4,5 \times 70 \times 3$

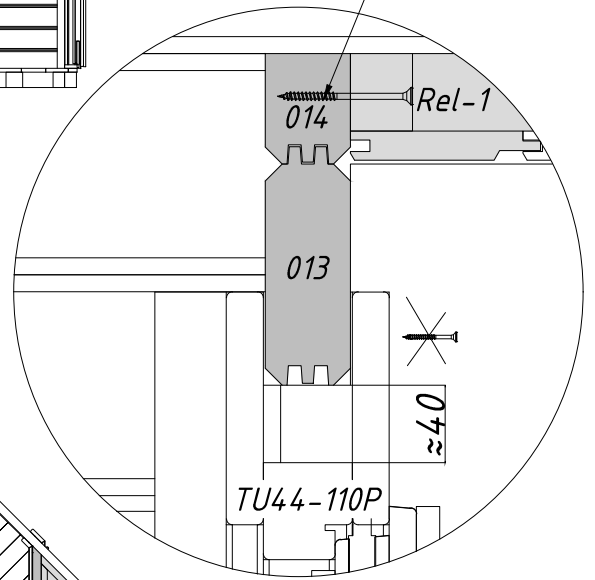

A

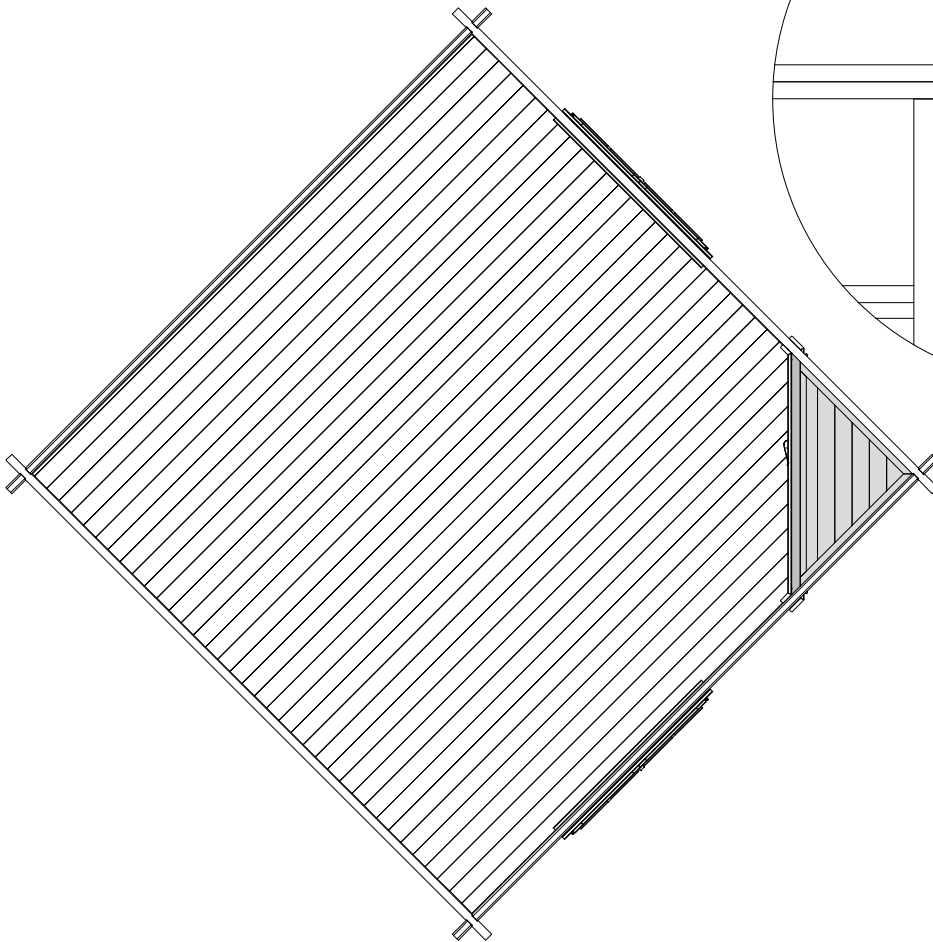

A

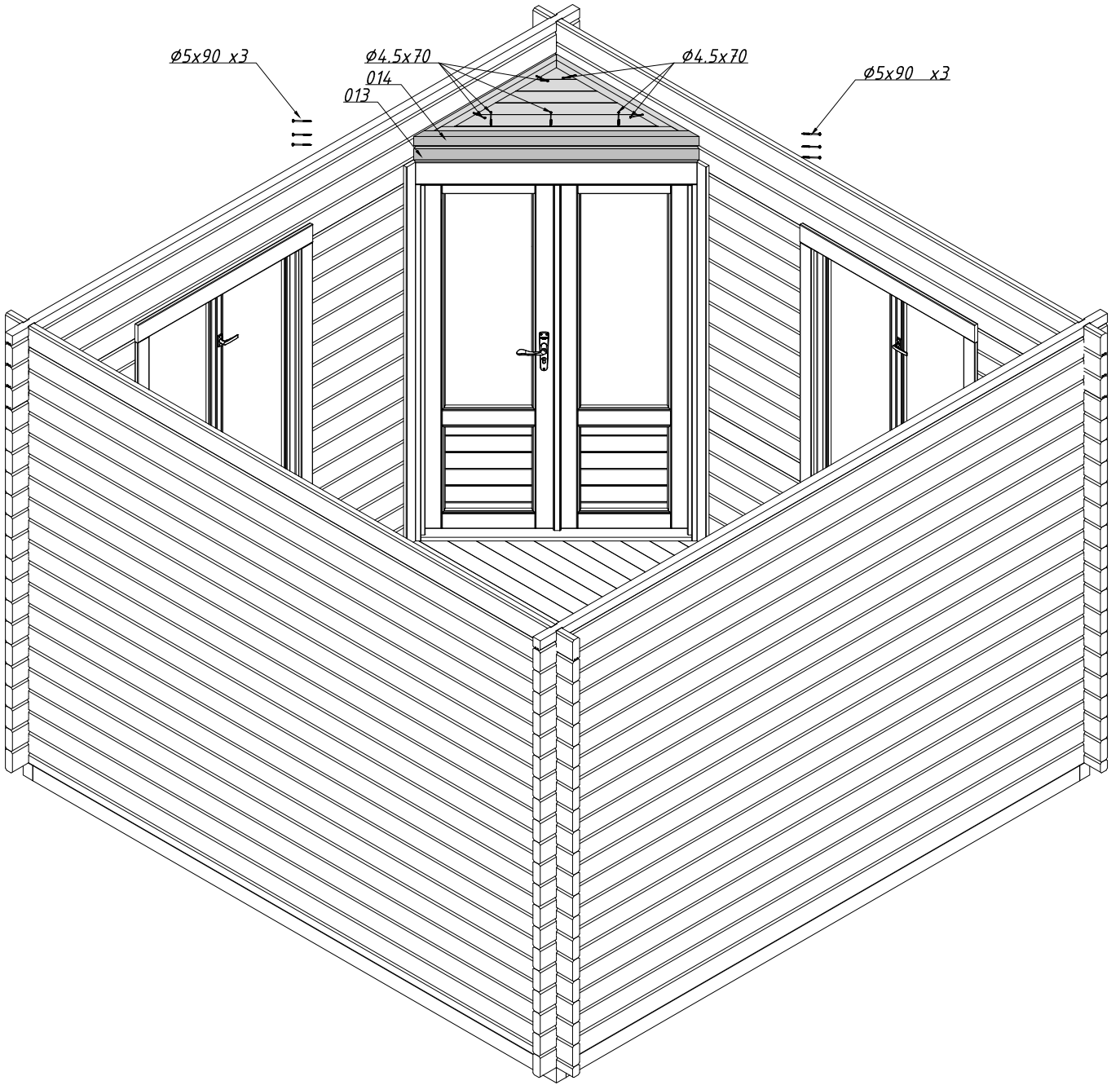

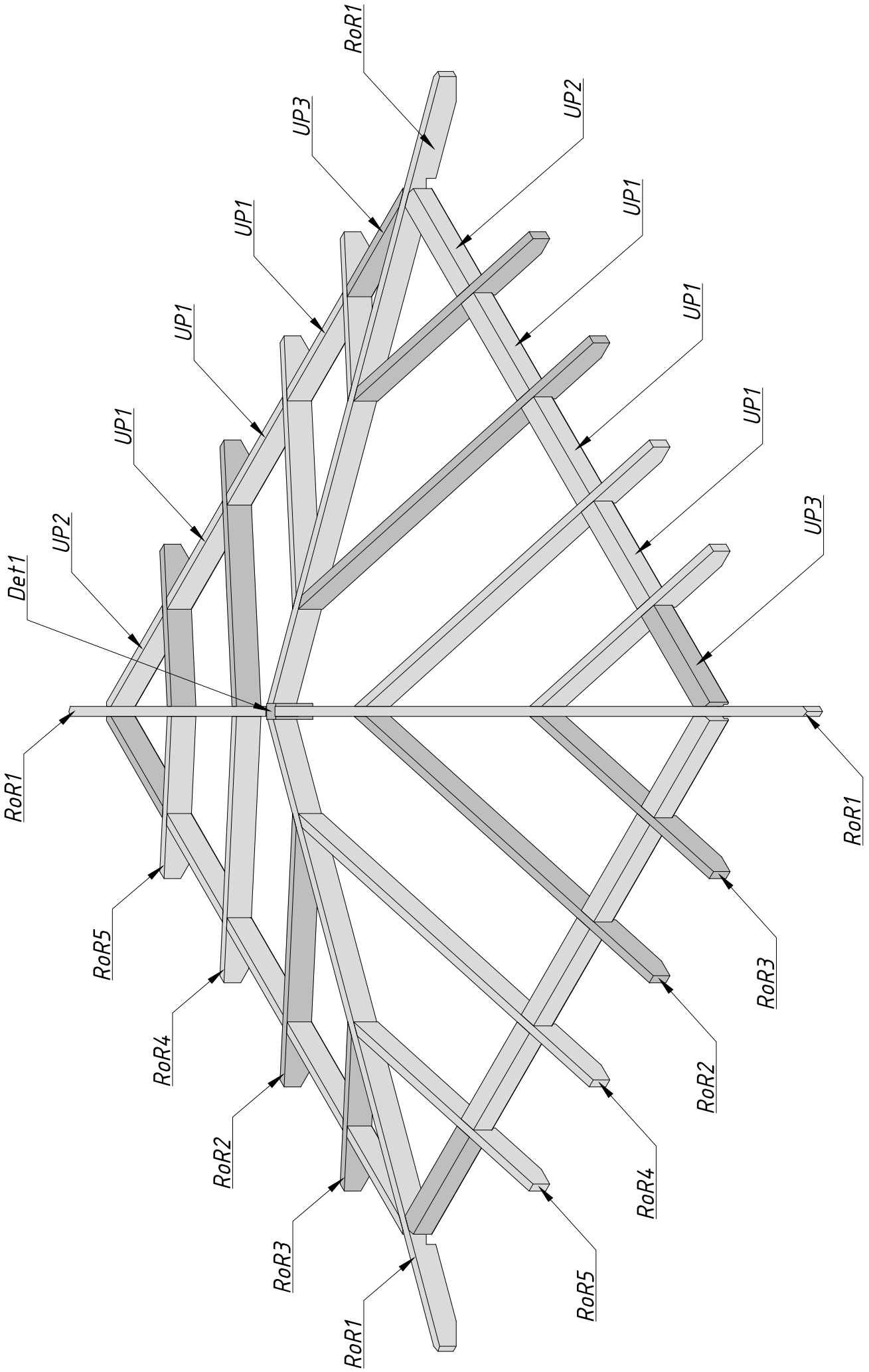

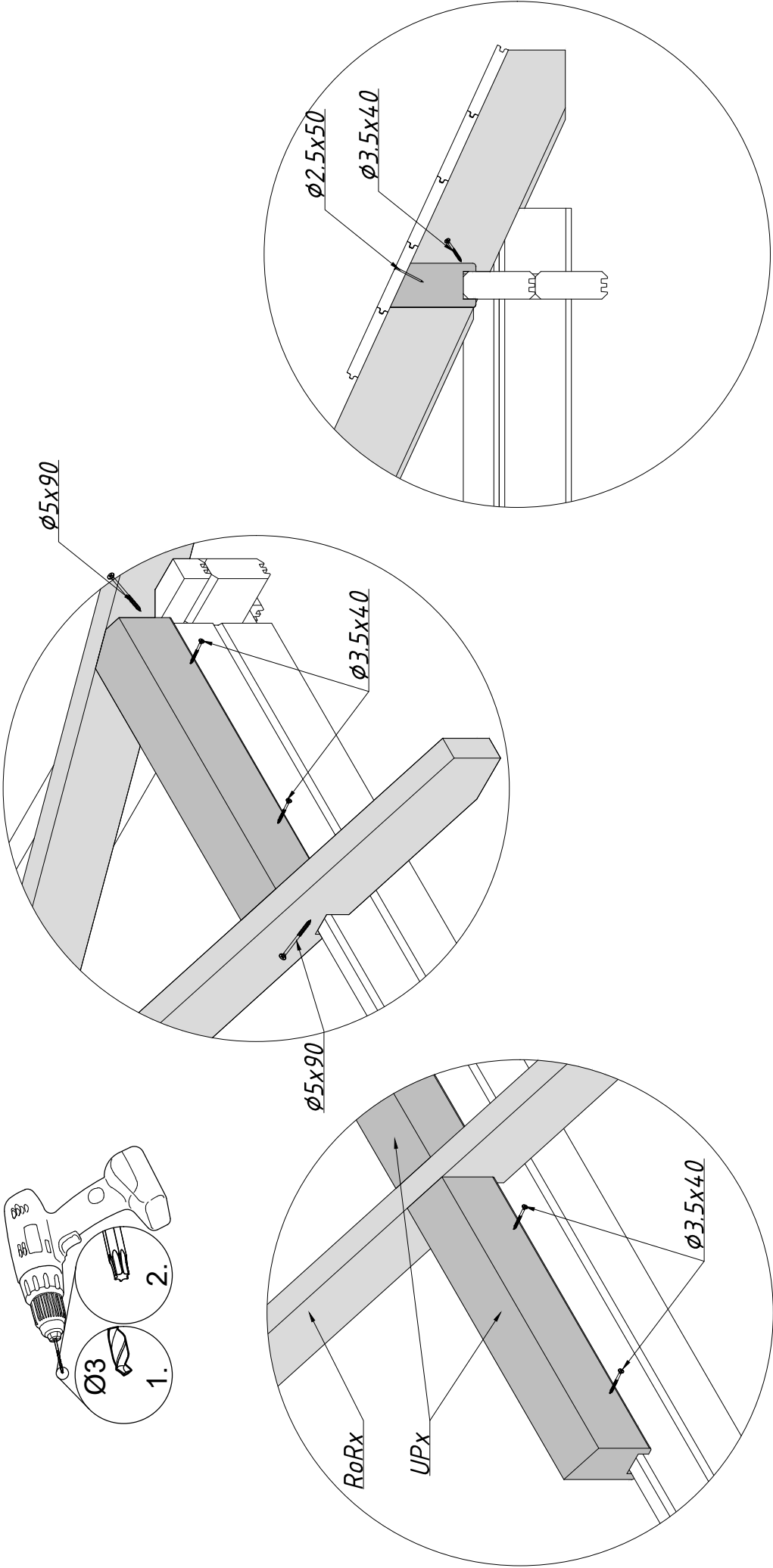

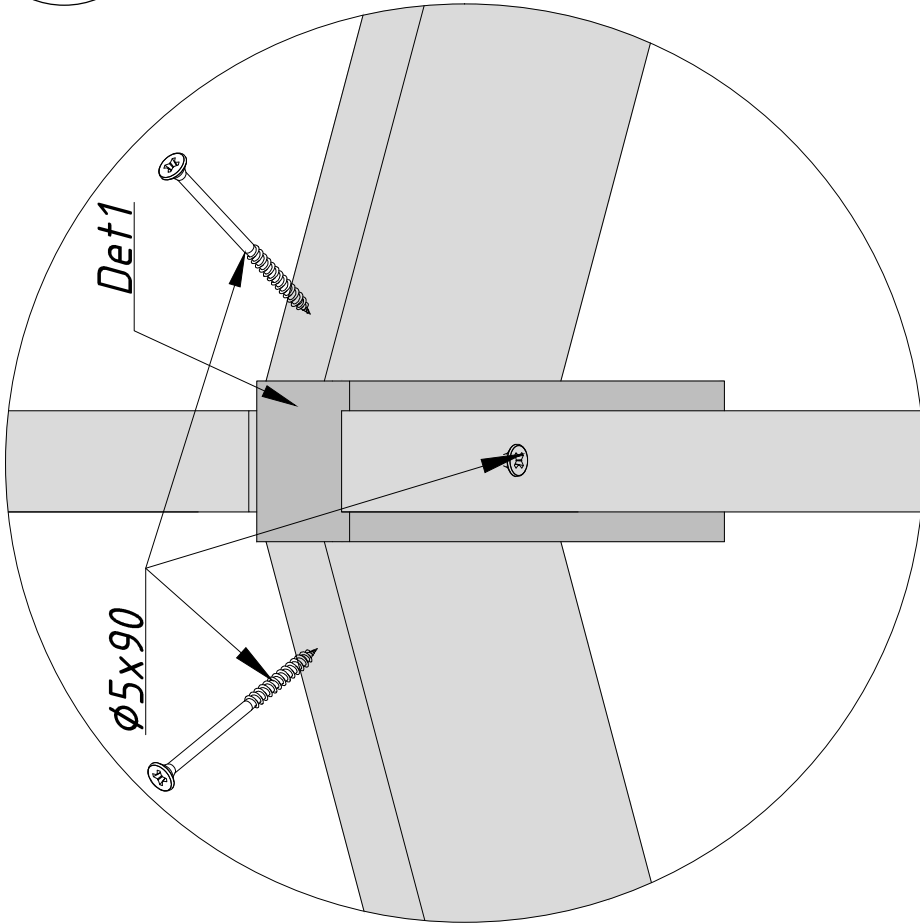
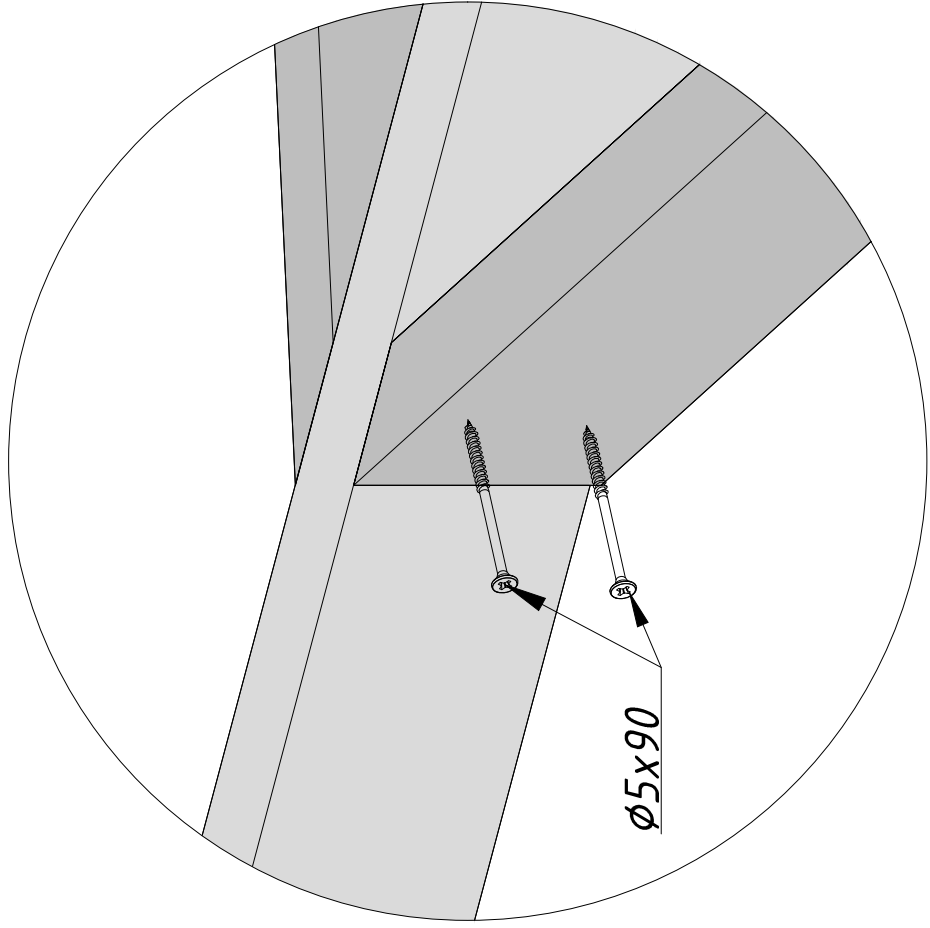
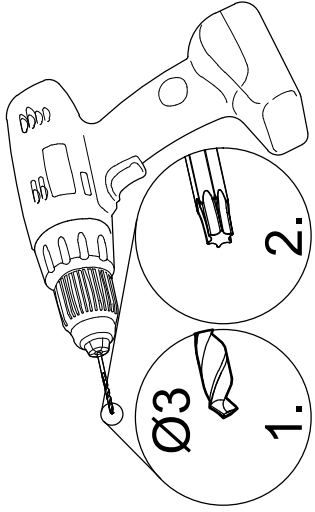

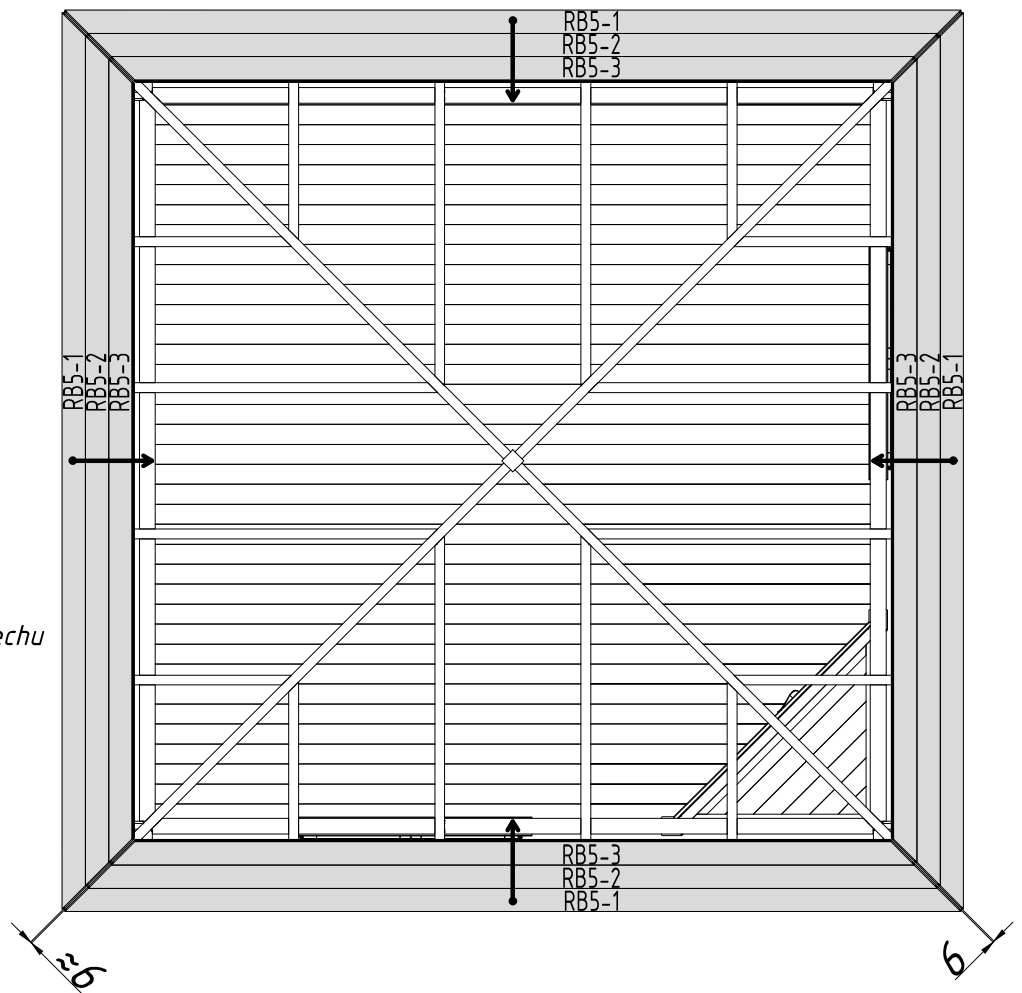
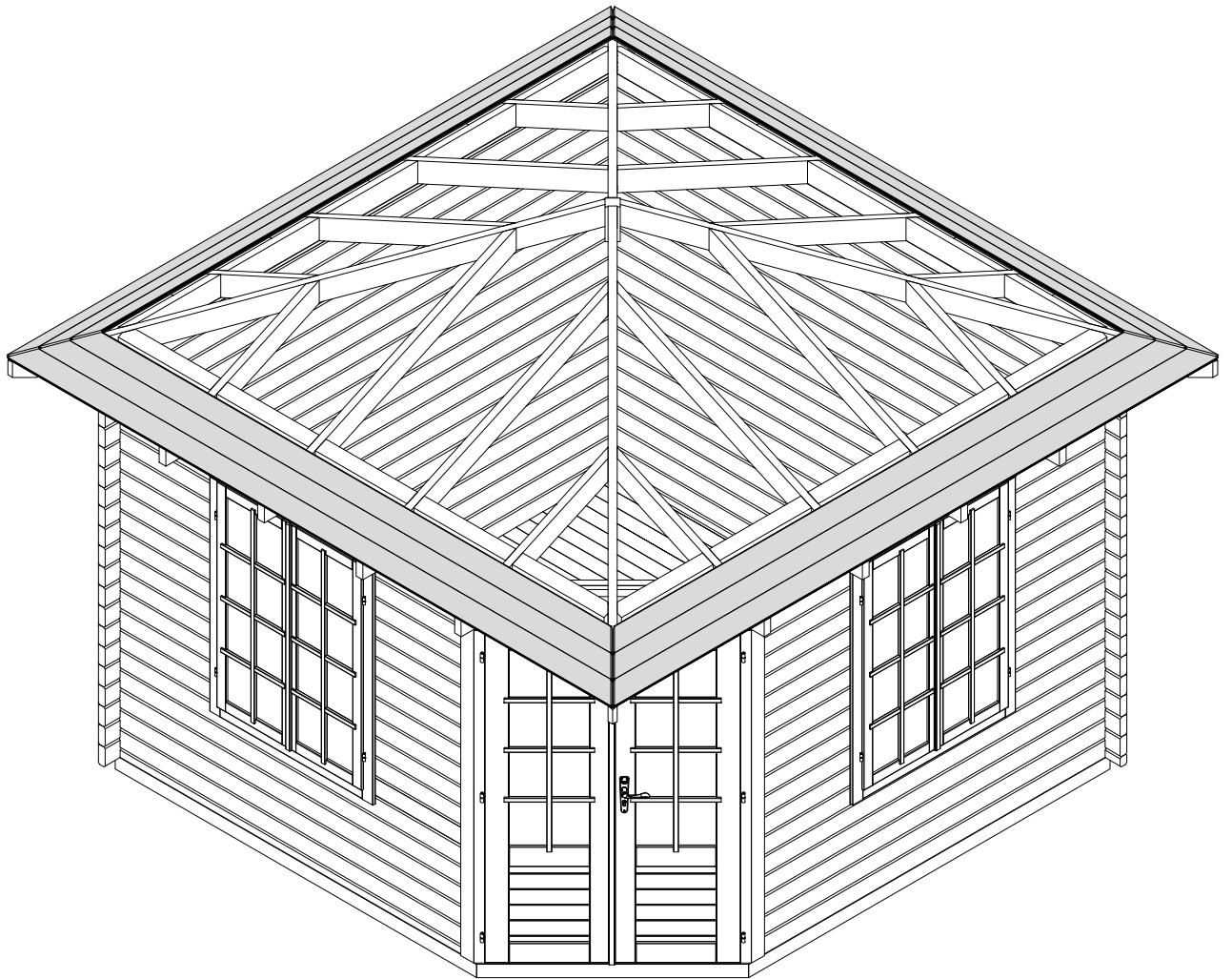

- EN *Roof boards*
- DE *Dachbretter*
- FR *Lames de toit*
- ES *Tablas de techo*
- IT *Tavole di tetto*
- NO *Takborden*
- SE *Takbrädor*
- FI *Kattolaudat*
- DK *Tagbrædder*
- NL *Dakbeschot*
- PT *Tábuas de telhado*
- CZ *Dřevěné desky na střechu*
- PL *Deski dachowe*
- LT *Stogo lentos*
- LV *Jumta dēļi*
- RU *Доски для крыши*
- ET *Katuselaud*

1.

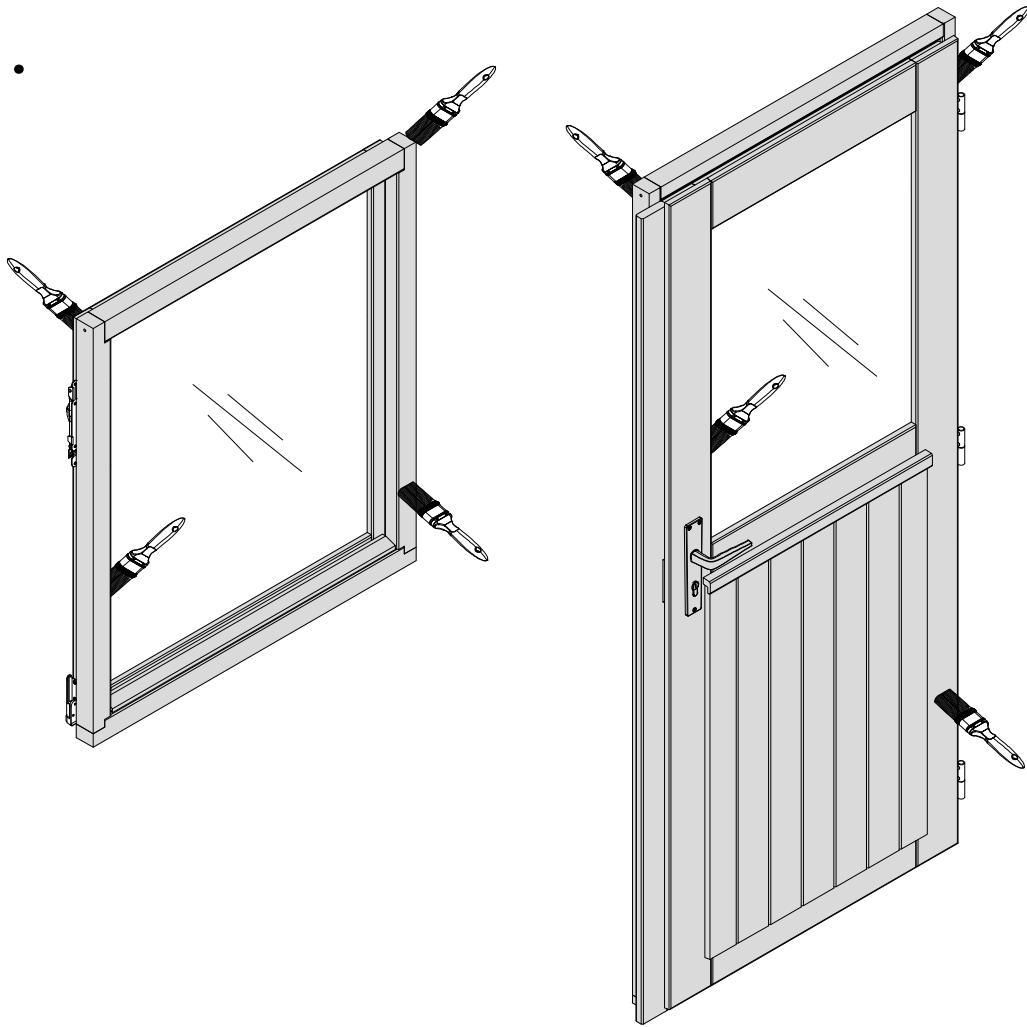

2.

